

ARMY TECHNICAL MANUAL TM 5-6350-264-14&P-12
NAVY PUBLICATION NAVELEX EE 181-AA-OMI-
120/E121 C-7359-60-1
AIR FORCE TECHNICAL ORDER T.O. 31S9-2FSS9-1-12

TECHNICAL MANUAL

**OPERATOR'S, ORGANIZATIONAL,
DIRECT SUPPORT AND GENERAL SUPPORT
MAINTENANCE MANUAL
(INCLUDING REPAIR PARTS AND
SPECIAL TOOLS LIST)**

RECEIVER, DATA R-1861/FSS-9(V)
NSN 6350-00-228-2655
AND
TRANSMITTER, DATA T-1257/FSS-9(V)
NSN 6350-00-251-5749

DEPARTMENTS OF THE ARMY, THE NAVY, AND THE AIR FORCE

30 AUGUST 1982

CHANGE }
No. 1 }

HEADQUARTERS
DEPARTMENTS OF THE ARMY, NAVY, AND AIR FORCE
WASHINGTON, D.C., 1 May 1986

Operator's Organizational, Direct Support, and General Support
Maintenance Manual
(Including Repair Parts and Special Tools List)

RECEIVER, DATA R-1861/FSS-9(V)
NSN 6350-00-228-2655
TRANSMITTER, DATA T-1257/FSS-9(V)
NSN 6350-00-251-5749

TM 5-6350-264-14&P-12, 30 August 1982, is changed as follows:

1. Title is changed as shown above. On cover and wherever "NAVELEX EE 181-AA-OMI-120/E121 C-7359-60-1" appears, it is changed to read "NAVELEX EE 181-AA-OMI-130/E121 R1861-T1257".

2. Remove and insert pages as indicated below. New or changed text material is indicated by a vertical bar in the margin. An illustration change is indicated by a miniature pointing hand.

Remove pages

i and ii
1-1 and 1-2
A-1 and A-2
B-3 and B-4
C-1 through C-5/C-6

Insert pages

i and ii
1-1 and 1-2
A-1 and A-2
B-3 and B-4
C-1 through C-14

3. Retain this sheet in front of manual for reference purposes.

TM 5-6350-264-14&P-12

NAVELEX EE 181-AA-OMI-13A/E121 R1861-T1257
TO 31S9-2FSS9-1-12

By Order of the Secretaries of the Army, the Navy, and the Air Force:

Official:

JOHN A. WICKHAM, JR.
General, United States Army
Chief of Staff

MILDRED E. HEDBERG
Brigadier General, United States Army
The Adjutant General

GLENWOOD CLARK
Vice Admiral, United States Navy
Commander, Naval Electronic
Systems Command

Official:

CHARLES A. GABRIEL, General USAF
Chief of Staff

EARL T. O'LOUGHLIN
General, USAF, Commander, Air Force
Logistics Command

GEORGE B. CRIST
Lieu tenant General, USMC
Deputy Chief of Staff for Installations and Logistics

Distribution:

To be distributed in accordance with DA Form 12-25A, Operator, Organizational, Direct Support and General Support Maintenance Requirements for Detection System, Joint Service, Interior Intrusion (JSIIDS) (TM 5-6350-264 Series)

WARNING

NOISE HAZARD

The Audible Alarm presents a noise hazard to personnel in the area. The noise level exceeds the allowable limits for unprotected personnel. Authorized protective equipment must be worn by all personnel in the work area. If the Audible Alarm is installed, it must be disabled BEFORE any troubleshooting procedures are attempted. Disable the alarm by setting the key-operated switch on Control Unit to TEST/RESET position, opening Audible Alarm, removing faceplate, and turning off power switch. After troubleshooting the Audible Alarm must be reactivated. Activate the Alarm by setting the key-operated switch on Control Unit to TEST/RESET position, turn Alarm power switch on, replace faceplate, close and lock Audible Alarm door. Turn key-operated switch on Control Unit to SECURE or ACCESS.

WARNING

RADIATION HAZARD

The Data Transmitter, and the Monitor Cabinet which contains the Data Receiver contains trace amounts of radioactive isotope, Promethium 147. The minute amount of ionizing radiation from Pm 147 is no health hazard when the equipment is installed or in storage; however, if it is necessary to dispose of a Data Receiver, the procedures specified in AR755-15 must be observed.

WARNING

HIGH VOLTAGE

High voltage is used in the operation of this equipment. Death on contact may result if personnel fail to observe safety precautions. A 115-volt ac potential may cause death under certain conditions; therefore, precautions should be taken at all times. Be careful not to contact connections for 115-volt ac input when installing or repairing this equipment. Never work on electronic equipment unless there is another person nearby who is familiar with the hazards of the equipment and who is competent in administering first aid.

WARNING

HYDROGEN GAS

The Monitor Cabinet contains a rechargeable battery which may generate ignitable amounts of hydrogen gas if certain failures occur. This is a potential safety hazard. Do not smoke when opening the door. After opening, allow the unit to ventilate with the door open for two minutes before turning off the Power Switch or performing any other maintenance action. If excessive heat or fumes of any nature are being emitted from the Monitor Cabinet, immediately open the enclosure door and ventilate for two minutes before performing any maintenance action.

HEADQUARTERS
 DEPARTMENTS OF THE ARMY, NAVY, AND AIR FORCE
 WASHINGTON, D.C., 30 August 1982

Operator's Organizational, Direct Support, and General Support
 Maintenance Manual
 (Including Repair Parts and Special Tools List)

RECEIVER, DATA R-1861/FSS-9(V)
 NSN 6350-00-228-2655
 TRANSMITTER, DATA T-1257/FSS-9(V)
 NSN 6350-00-251-5749

Current as of 2 August 1985

You can help improve this manual. If you find any mistake or if you know of a way to improve the procedures, please let us know. ARMY: Your letter or DA Form 2028 (Recommended Changes to Publications and Blank Forms) located in the back of this manual should be mailed directly to: Commander, U.S. Army Troop Support Command, ATTN: AMSTR-MCTS, 4300 Goodfellow, St. Louis, MO 63120-1798. AIRFORCE: Completed AFTO Form 22 (Technical Order Publication Improvement Report and Reply) should be forwarded to: HQ, SA-ALC/MMEDT, Kelly AFB, TX 78241. NAVY: COMPLETED DA Form 2028 (Recommended Changes to Publications and Blank Forms), User Activity Technical Manual Comment Sheet Feedback Report, or other suitable reporting form should be mailed to: Naval Electronics Systems Command Training and Publications Management Office, ATTN: ELEX, Code 8122, Washington, DC 20360.

		Paragraph	Page
CHAPTER 1.	INTRODUCTION		
Section I.	General.....	1-1	1-1
II.	Description and data	1-8	1-1
CHAPTER 2.	OPERATING INSTRUCTION		
Section I.	Operating procedures.	2-1	2-1
II.	Theory of operation.	2-3	2-1
CHAPTER 3.	OPERATOR MAINTENANCE INSTRUCTIONS		
Section I.	Lubrication instructions (Not Applicable)		
II.	Preventive maintenance checks and services (PMCS).	3-1	3-1
III.	Troubleshooting (Not Applicable)		
IV.	Maintenance (Not Applicable)		
CHAPTER 4.	ORGANIZATIONAL MAINTENANCE INSTRUCTIONS (Not Applicable)		
CHAPTER 5.	DIRECT SUPPORT AND GENERAL SUPPORT MAINTENANCE INSTRUCTIONS		
Section I.	Repair parts, special tools and equipment.	5-1	5-1
II.	Troubleshooting	5-3	5-1
III.	General Maintenance	5-4	5-2
IV.	Removal and replacement of major components and assemblies	5-5	5-2
CHAPTER 6.	REPAIR OF DATA TRANSMITTER AND DATA RECEIVER (Not Applicable)		
APPENDIX A.	REFERENCES		A-1
B.	MAINTENANCE ALLOCATION CHART		B-1
C.	ORGANIZATIONAL, DIRECT SUPPORT, AND GENERAL SUPPORT MAINTENANCE REPAIR PARTS AND SPECIAL TOOLS LIST INCLUDING DEPOT MAINTENANCE REPAIR PARTS AND SPECIAL TOOLS).		C-1

TM 5-6350-264-14&P-12

NAVELEX EE 181-AA-OMI-13A/E121 R1861-T1257

TO 31S9-2FSS9-1-12

	Paragraph	Page
Section I.	INTRODUCTION	C-1
II.	Repair Parts List.....	C-9
Group 01.	Data Receiver.....	C-9
02.	Data Transmitter.....	C-11
Section III.	Special Tools List (Not Applicable).....	C-12
IV.	National Stock Number and Part Number Index.....	C-13

List of Illustrations

Figure	Title	Page
1-1	Data Transmitter and Data Receiver	1-2
1-2	Data Transmitter, Exploded View.	1-3
1-3	Data Receiver, Exploded View.	1-4
1-4	Identification Plate, Transmitter.	1-6
1-5	Identification Plate, Receiver	1-6
2-1	DTS-1 Simplified Block Diagram	2-2
5-1	Data Receiver	5-3
5-2	Data Receiver PC Boards With Troubleshooting Test Points.	5-4
5-3	Data Transmitter With Troubleshooting Test Points.	5-5
C-1.	Data Receiver R-1861/FSS-9(V)	C-8
C-2.	Data Transmitter T-1257/FSS-9(V).....	C-9

List of Tables

Number	Title	Page
5-1	Troubleshooting Procedures	5-6

CHAPTER 1 INTRODUCTION

Section I. GENERAL

1-1. SCOPE. This manual is for your use in operating and maintaining the Data Transmitter, Model T-1257/FSS-9(V) and Data Receiver, Model R-1861/FSS9(V) under normal operating conditions. The transmitter and receiver form the Data Transmission System Type 1 (DTS-1) and are an integral part of the Joint Services Interior Intrusion Detection System (J-SIIDS). For information on the major components of J-SIIDS, refer to the applicable manual listed in appendix A.

1-2. MAINTENANCE FORMS AND RECORDS. Equipment maintenance forms and procedures for their use are contained in DA PAM 738-750, The Army Maintenance Management System (TAMMS).

1-3. ADMINISTRATIVE STORAGE. Instructions for administrative storage are contained in TM 740-90-1.

1-4. DESTRUCTION OF ARMY MATERIEL TO PREVENT ENEMY USE. Instructions for the des-

truction of Army materiel to prevent enemy use are contained in TM 750-244-3.

1-5. QUALITY ASSURANCE/QUALITY CONTROL. There are no Quality Assurance/Quality Control technical manuals applicable to this equipment.

1-6. REPORTING EQUIPMENT IMPROVEMENT RECOMMENDATIONS (EIR). EIR's will be prepared on Standard Form 368, Quality Deficiency Report. Instructions for preparing EIR's are provided in DA PAM 738-750. EIR's should be mailed directly to Commander, U.S. Army Troop Support Command, ATTN: AMSTR-QX, 4300 Good fellow Blvd., St. Louis, MO. 63120-1798.

1-7. EQUIPMENT SERVICEABILITY CRITERIA (ESC). This equipment is not covered by an ESC.

Section II. DESCRIPTION AND DATA

1-8. DESCRIPTION.

- a. The Data Transmission System Type 1 (DTS-1) consists of the Data Transmitter, Data Receiver (fig. 1-1), and the interconnecting transmission lines. The Transmitter receives power from and is mounted inside the J-SIIDS Control Unit. The Receiver plugs into the Status Monitor Module, and these two items receive power from and mount inside the J-SIIDS Monitor Cabinet.
- b. The Data Transmitter (fig. 1-2) consists of three PC boards stacked on an aluminum baseplate and covered by an aluminum case. Terminal strip TB1 and sever-

al electronic components are mounted on the baseplate outside of the case. A code plug, which is one-half of a matched pair, is plugged into a socket on PC board A-2. The matching plug is mounted in the Data Receiver.

- c. The Data Receiver (fig. 1-3), which plugs into the Status Monitor Module, consists of an aluminum interconnecting sub-assembly with four plug-in PC boards, a line-fault indicator, and a line-fault, reset switch. A code plug, which is one-half of a matched pair, is plugged into a socket on one of the PC boards. The matching plug is mounted in the Data Transmitter.

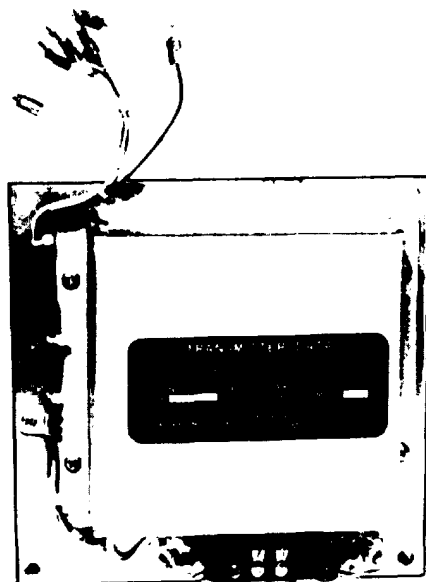

TRANSMITTER

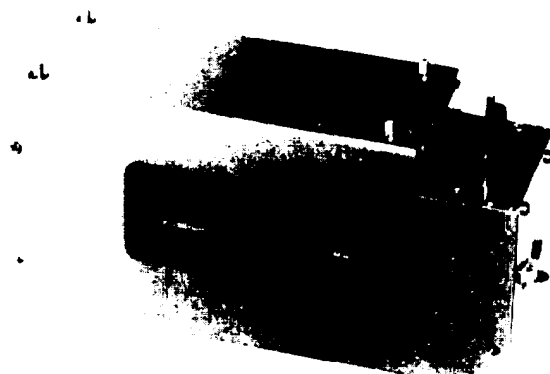

RECEIVER

Figure 1-1. Data Transmitter and Data Receiver

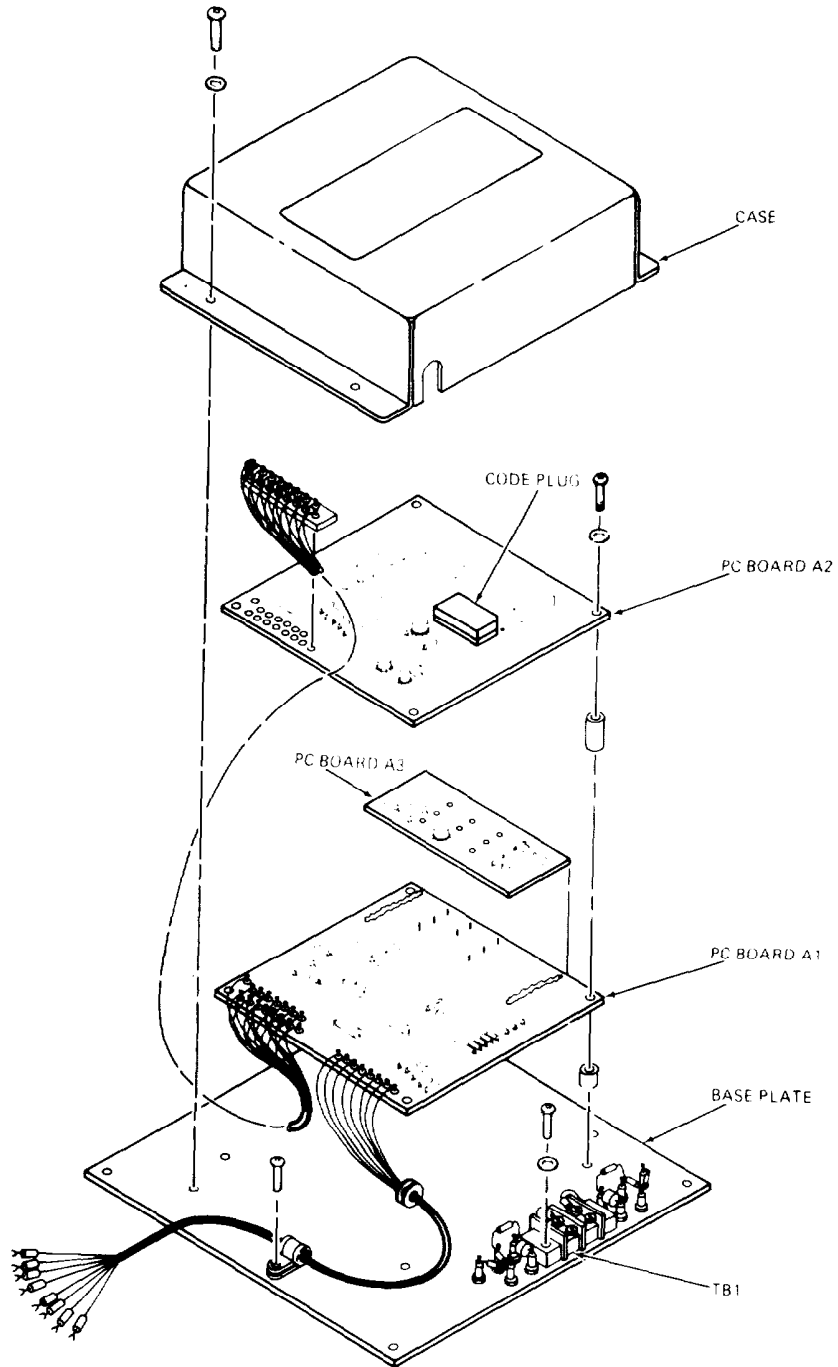

Figure 1-2. Data Transmitter, Exploded View

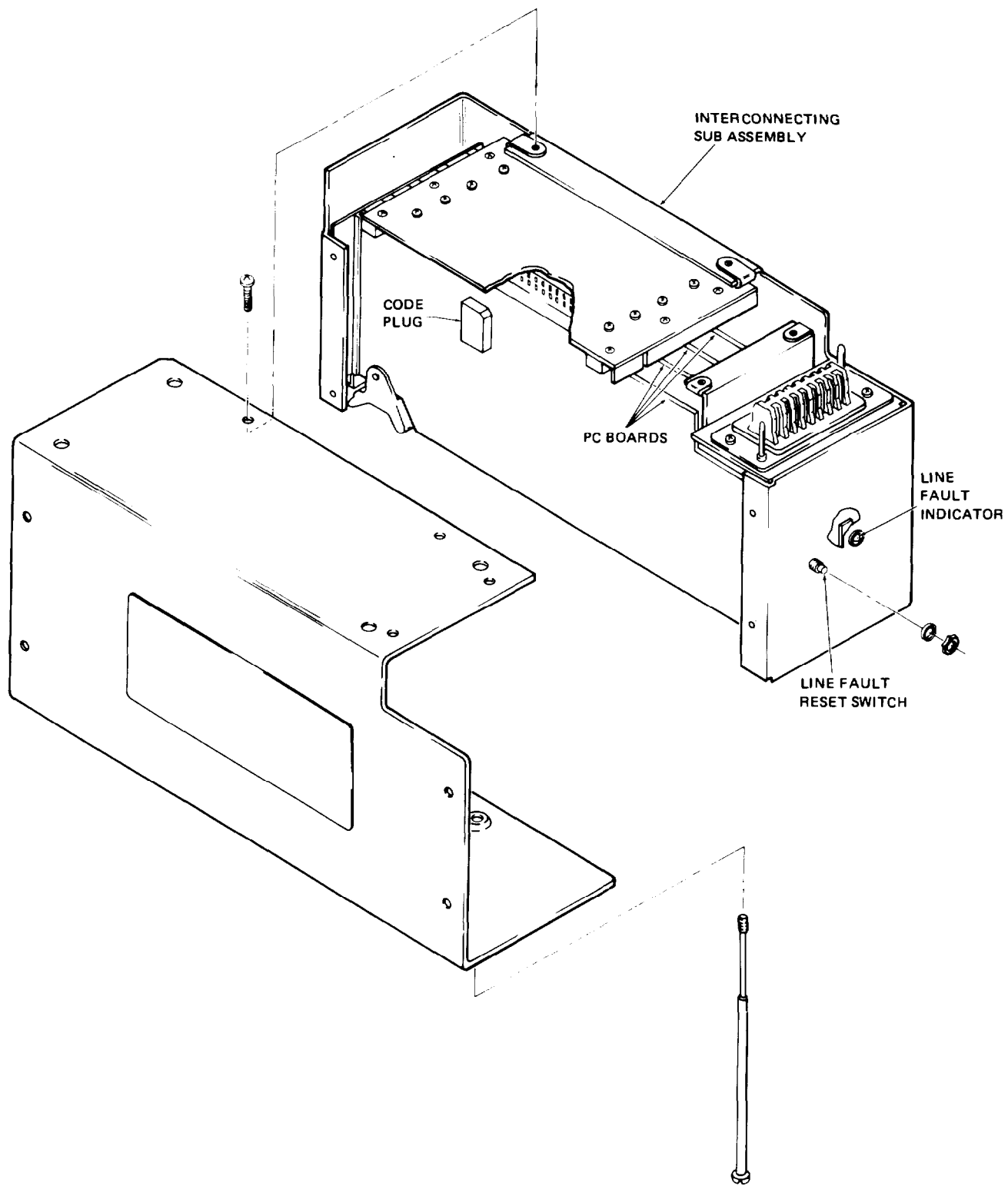

Figure 1-3. Data Receiver, Exploded View

1-9. TABULATED DATA.

a. Identification Data. An identification plate is mounted on the side of the Data Transmitter (fig. 1-4) and the Data Receiver (fig. 1-5).

b. Equipment Characteristics.

(1) Transmitter.

Weight.20 ounces (560 g)

Dimensions (overall)

Height. 1.20 inches (3.75 cm)

Width 7.81 inches (19.5 cm)

Length 7.81 inches (19.5 cm)

Housing finish. Chemical film in accordance with MIL-C-5541

Class 3

Power requirements 20 ±2 vdc at 15 ma; supplied by J-SIIDS

Control Unit

Number of inputs 4

Instantaneous alarm . . . Alarm-over 100,000 ohms/No alarm-less than 2,000 ohms

Latched alarm. Alarm-over 100,000 ohms/No alarm-less than 2,000 ohms

Secure/Access Secure-over 100,000 ohms/Access-less than 2,000 ohms

AC Power Power fail-over 100,000 ohms/Power on-less than 2,000 ohms

Number of outputs 1

Output level 0.70 dbm min to +2.5 dbm max, with four 4 ±0.5 db steps

Output impedance 600 ohms balanced

Baud rate 12 Hz

Type of transmission. . . Monologue, time division multiplex (TDM), frequency shift keying (FSK), 12-bit code

FSK logic tones. 1070 Hz = logic 0
 1270 Hz = logic 1

(2) Receiver.

Weight. 2 pounds (0.9 kg)

Dimensions (overall)

Height. 3.94 inches (9.9 cm)

Width 2.69 inches (6.7 cm)

Length 8 inches (20.3 cm)

Housing finish. Chemical film in accordance with MIL-C-5541

Class 3

Power requirements 20 ± 2 vdc at 25 ma; supplied by J-SIIDS

Monitor Module

Number of inputs 1

Input impedance. 600 ohms balanced

Number of outputs 3

Alarm Alarm-over 100,000 ohms/No alarm-less than 2,000 ohms

Secure/Access Secure-over 100,000 ohms/Access-less than 2,000 ohms

AC Power Power fail-over 100,000 ohms/Power on-less than 2,000 ohms

Input level. +2 dbm to -45 dbm

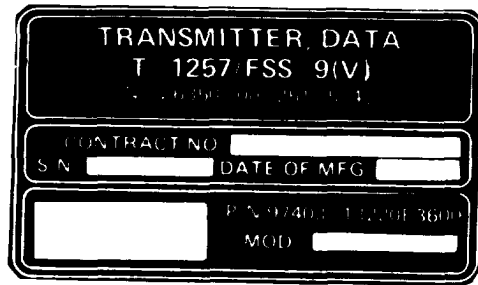

Figure 1-4. Identification Plate, Transmitter

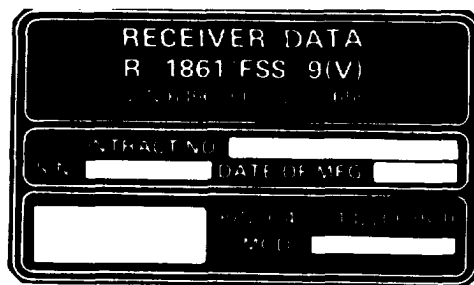

Figure 1-5. Identification Plate, Receiver

Input bandwidth. 6 ±2 db from 400
to 1500 Hz

FSK logic tones. 1070 Hz = logic 0
1270 Hz = logic 1

(3) DTS-I characteristics.

Environmental (operational)

Temperature range -20° to +150°F
(-29° to +65°C)

Relative humidity Up to 95%

Environmental (nonoperational and storage)

Temperature range -30° to +165°F
(-34° to +74°C)

Relative humidity Up to 90%

Shock 20 g for 11 ms and
bench handling

Vibration Withstands transportation
conditions

Weather resistance. Designed for
interior installation

CHAPTER 2

OPERATING INSTRUCTIONS

Section L OPERATING PROCEDURES

This section is not applicable.

2-1. NORMAL OPERATING PROCEDURES. The Transmitter and Receiver are operational after they have been installed, tested, and connected in the J-SIIDS configuration. Since the startup and shut-

down of the Transmitter and Receiver are dependent on the presence or absence of power from the Control Unit and Monitor Cabinet respectively, no operating procedures are required.

Section IL THEORY OF OPERATION

2-2. FUNCTIONAL DESCRIPTION. The Data Transmitter and Receiver provide secure transmission and line supervision between the J-SIIDS Control Unit and Monitor Cabinet. The Transmitter monitors the status of the Control Unit and sends status information to the Receiver by means of a 12-bit word stream. The Receiver decodes the status information and provides input to the Status Monitor Module which displays the secure or alarm condition at the front panel of the J-SIIDS Monitor Cabinet. Figure 2-1 is a simplified block diagram. The method of transmission is over a balanced, 2-wire transmission line up to 10 miles

long or over leased, dedicated, voice-grade telephone lines. The one-zone, five-zone and twenty-five-zone Monitor Cabinets are functionally identical.

2-3. EMERGENCY OPERATION. Extended periods of operation on battery (stand-by) power should be avoided.

2-4. UNUSUAL OPERATING CONDITIONS. Loss of synchronization between Data Transmitter and Data Receiver may occur while operating during periods of heavy thunderstorms.

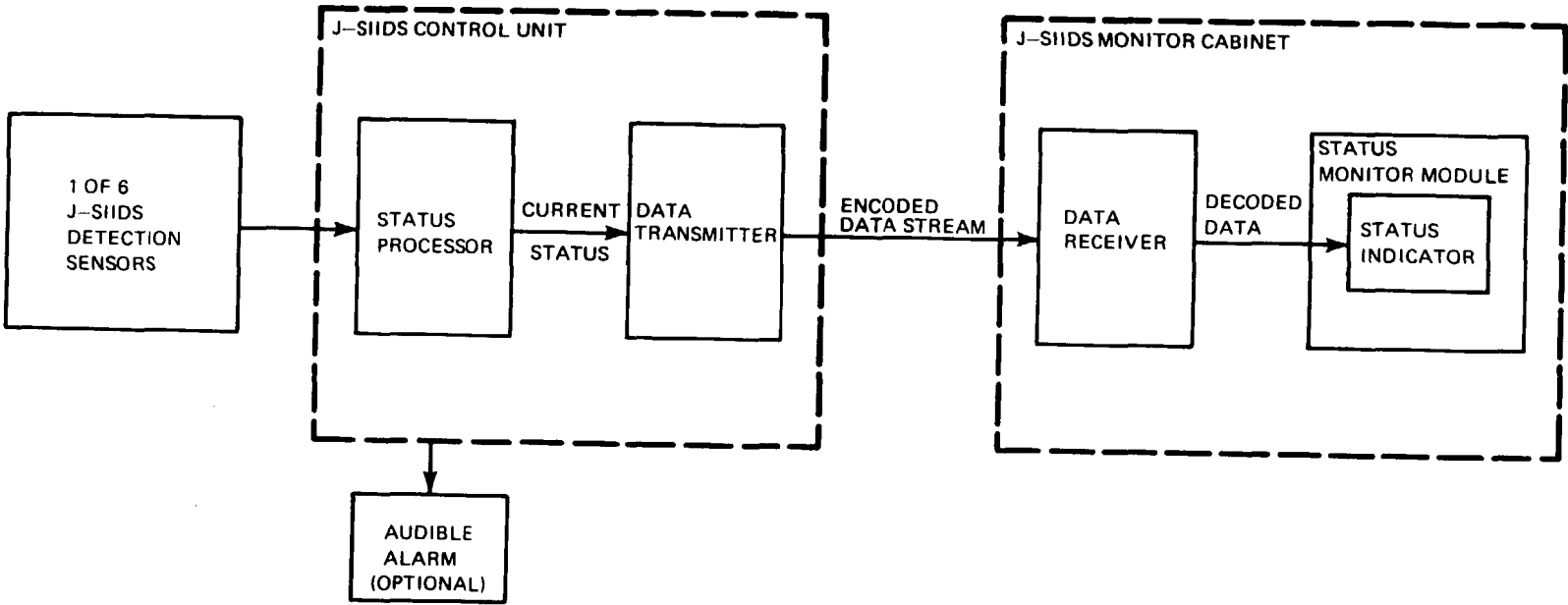

Figure 2-1. DTS-1 Simplified Block Diagram

CHAPTER 3
OPERATOR MAINTENANCE INSTRUCTIONS

Section I. LUBRICATION INSTRUCTIONS

This section is not applicable.

Section II. PREVENTIVE MAINTENANCE, CHECKS, AND SERVICES (PMCS)

3-1. PREVENTIVE MAINTENANCE. Clean external surfaces with cloth dampened with water and mild detergent. Rinse with cloth dampened in cold water. Dry with lint-free cloth.

Section III. TROUBLESHOOTING

This section is not applicable.

Section IV. MAINTENANCE

This section is not applicable.

CHAPTER 4

ORGANIZATION MAINTENANCE INSTRUCTIONS

This chapter is not applicable to this equipment.

CHAPTER 5

DIRECT SUPPORT AND GENERAL SUPPORT MAINTENANCE INSTRUCTIONS

Section I. REPAIR PARTS, SPECIAL TOOLS AND EQUIPMENT

5-1. SPECIAL TOOLS. No special tools are required for the Data Transmission System.

5-2. REPAIR PARTS. Repair parts are listed and illustrated in the repair parts and special tools list covering direct and general support maintenance for this equipment in appendix C of this manual.

Section II. TROUBLESHOOTING

5-3. TROUBLESHOOTING PROCEDURES.

WARNING

The Audible Alarm presents a noise hazard to personnel in the area. The noise level exceeds the allowable limits for unprotected personnel. Authorized protective equipment must be worn by all personnel in the work area.

NOTE

If the Audible Alarm is installed, it must be disabled BEFORE any troubleshooting procedures are attempted. Disable the alarm by setting the key-operated switch on Control Unit to TEST/RESET position. Open Audible Alarm, remove faceplate, and turn off power switch. After troubleshooting, the Audible Alarm must be reactivated. Activate the Alarm by setting the key-operated switch on Control Unit to TEST/RESET position. Turn Alarm power switch on, replaces faceplate, close and lock Audible Alarm door. Turn key-operated switch on Control Unit to SECURE or ACCESS.

- a. This section contains troubleshooting information for locating and correcting most of the operating troubles which may develop in the Data Transmission System. Each malfunction for an individual component, unit, or system is followed by a list of tests or inspections which will help you to determine corrective actions to take. You should perform the test/inspections in the corrective actions column in the order listed.
- b. This manual cannot list all malfunctions that may occur, nor all tests or inspections and corrective actions. If a malfunction is not listed or is not corrected by listed corrective actions, notify your supervisor.
- c. The table lists the common malfunctions which you may find during the operation or maintenance of the Data Transmission System or its components. You should perform the test/inspections in the corrective actions column in the order listed.

NOTE

Before you use table 5-1, be sure you have performed all applicable operating checks.

- d. Check all available information on the equipment for aid in diagnosing problems.
- e. Make a visual inspection of the equipment.
 - (1) Inspect the equipment for evidence of physical damage.
 - (2) Inspect the terminal strips for clean and secure connections.
 - (3) Inspect all wiring and cabling for worn or frayed insulation and broken wires.
 - (4) Inspect all resistors for discoloration due to overheating.
 - (5) Inspect the complete subsystem for the presence of dirt, corrosion, moisture, and bits of wire or solder inside the housings.

NOTE

Touchup paint is recommended instead of refinishing whenever practical.

- (6) Inspect all metal surfaces intended to be painted for condition of finish and legibility of panel lettering.

- f. Refer to figures 5-1, 5-2, and 5-3 for all test points referred to in table 5-1. Step-by-step troubleshooting procedures, including Trouble, Probable Cause, and Corrective Action, are listed in table 5-1.

NOTE

The one-zone, five-zone, and twenty-five-zone Control Monitors are functionally identical and the troubleshooting procedures are the same for all three.

Section III. GENERAL MAINTENANCE

5-4. MAINTENANCE ACTION. The extent of direct and general support maintenance is governed by the Maintenance Allocation Chart (MAC), Appendix B. The MAC authorizes on-site test and replacement of the Data Transmitter, the Data

Receiver, the code plugs in both the Transmitter and Receiver, and interconnecting wiring. Periodic testing of the Data Transmission System is not scheduled because the J-SIIDS is maintained in continuous operation.

Section IV. REMOVAL AND REPLACEMENT OF MAJOR COMPONENTS AND ASSEMBLIES

5-5. REMOVAL AND INSTALLATION PROCEDURES.

- a. To remove Data Transmitter, unlock and open Control Unit (CU) door. Tag and disconnect Data Transmitter wires from TB6 and TB7. Remove screws that secure Transmitter to standoffs in CU. Be careful not to drop Transmitter inside CU.
- b. To replace Data Transmitter, position Transmitter over standoffs in the CU

and insert screws. Tighten the screws to secure Transmitter. Connect wires to TB6 and TB7 per tags on wires removed from these terminals.

- c. To remove Data Receiver, unlock and open Monitor Cabinet, and turn off switch S1 on power supply. Release swingout rack. Remove screws that secure status monitor module to rack and remove module through front of rack. Loosen captive screws and remove Data Receiver from bottom of module.

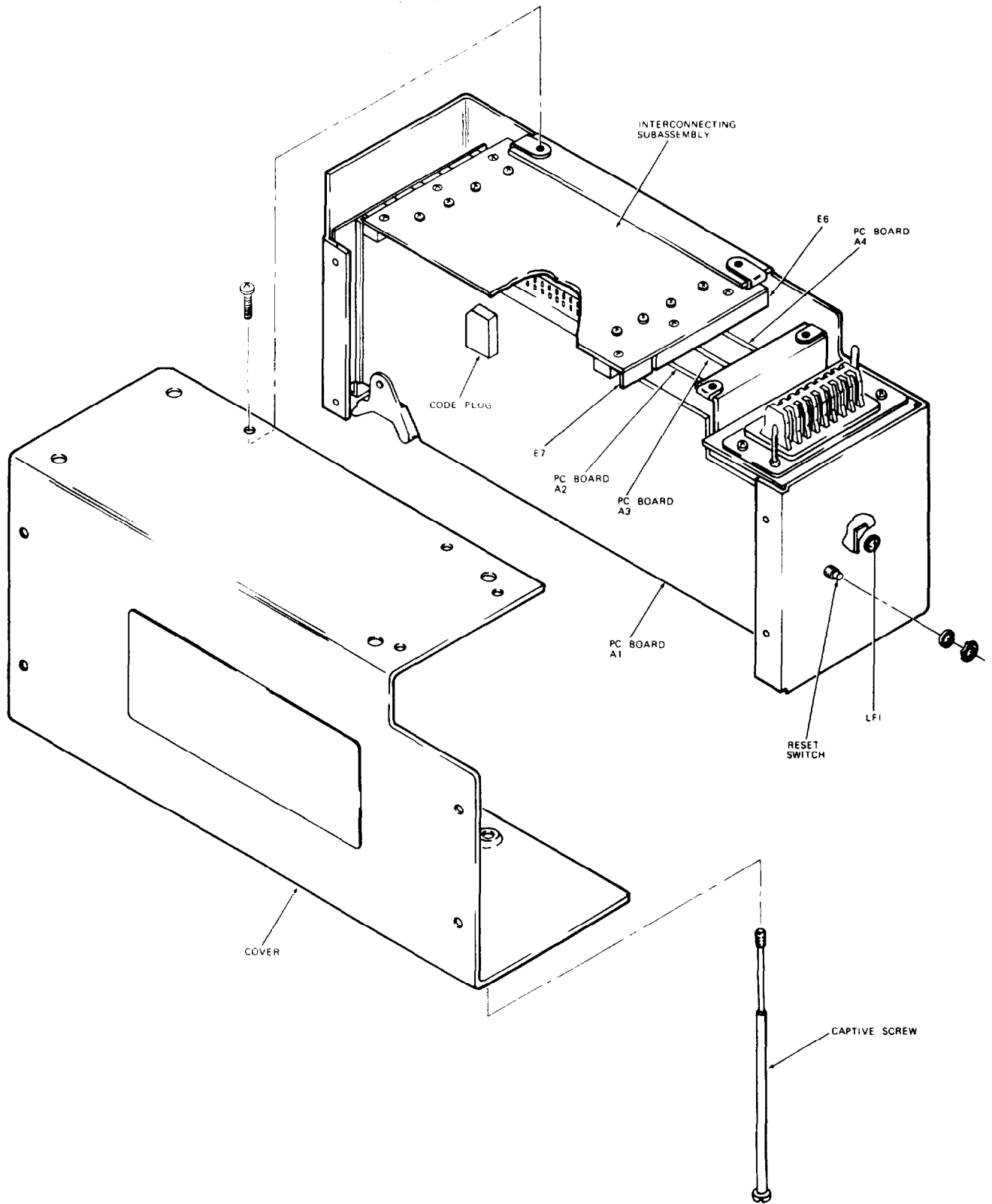

Figure 5-1. Data Receiver

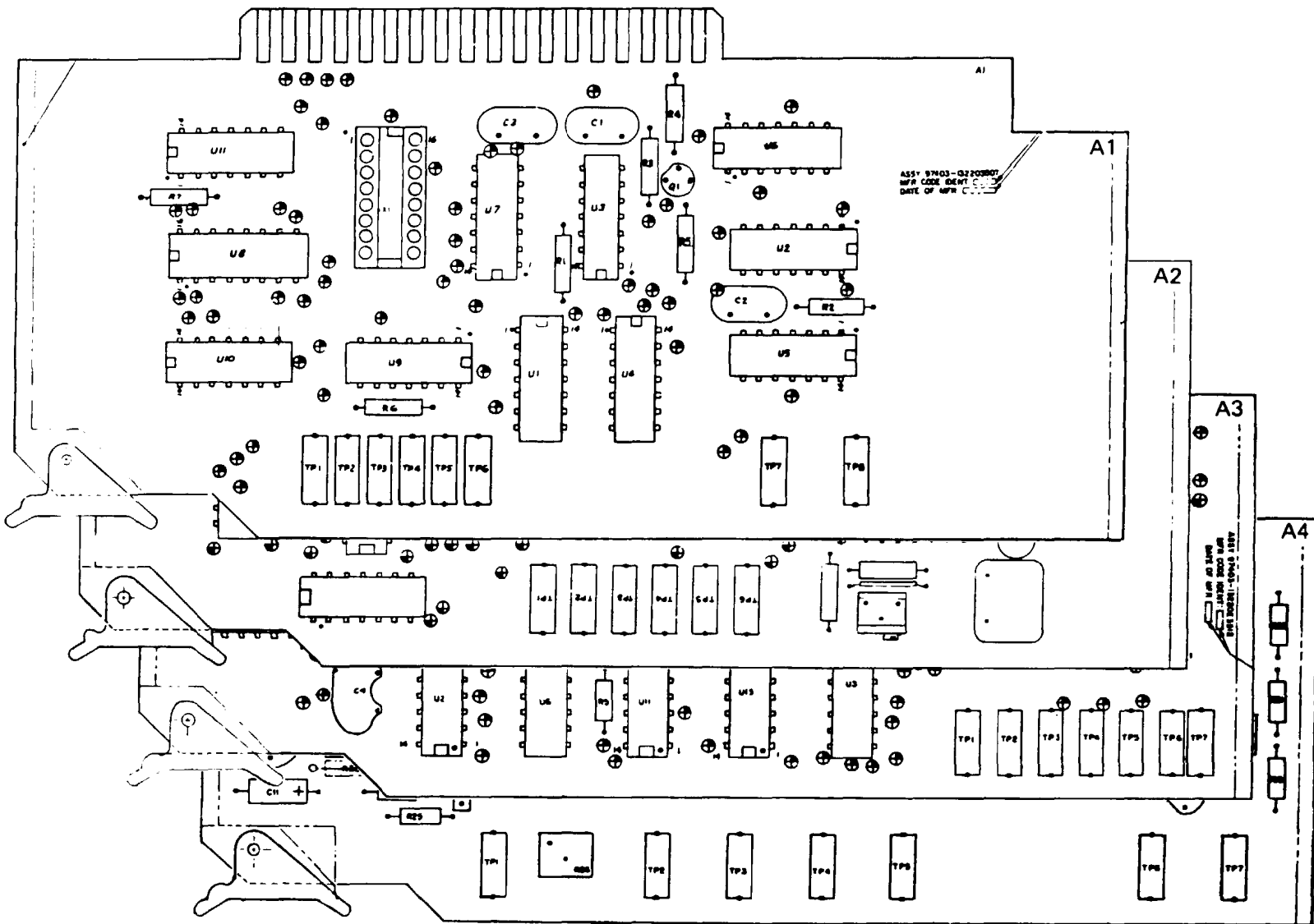

Figure 5-2. Data Receiver PC Boards With Troubleshooting Test Points

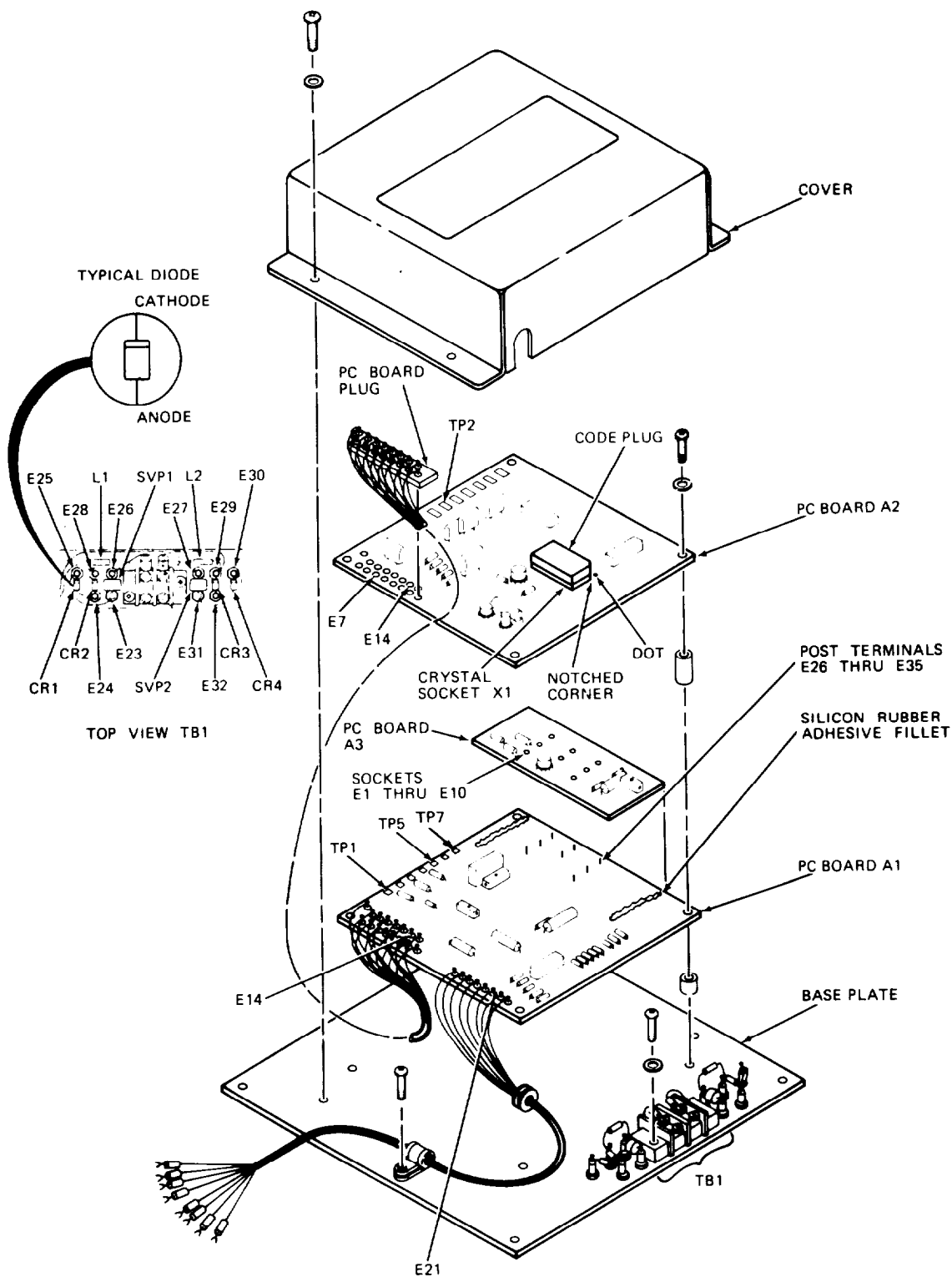

Figure 5-3. Data Transmitter With Troubleshooting Test Points

NOTE

Troubleshooting procedures listed in table 5-1 may require more than one person to perform corrective action.

Covers should be removed as necessary to perform troubleshooting procedures.

Never disconnect a wire without first marking that wire to assure proper reconnection.

Table 5-1. Troubleshooting Procedures

Trouble	Probable cause	Corrective action
1. Constant alarm or no alarm.	a. Bad wiring between Data Transmitter and CU.	<p style="text-align: center;">CAUTION</p> <p>During troubleshooting, ensure that only correct test points are used. If power is applied to wrong point, or if wrong point is shorted to ground, the equipment will be damaged.</p> <p>a. Tag, remove and insulated Data Transmitter wires from TB6 and TB7 in Control Unit (CU).</p> <p>b. Set multimeter to ohms and connect leads to any two of these wires, (except black and gray wires). Note meter indication and reverse leads. Meter should indicate 45,000 to 55,000 ohms in both directions. Repeat these steps for all wires.</p> <p>c. If any of these indications are not correct, replace Data Transmitter.</p> <p>(1) To remove Data Transmitter, remove screws that secure Data Transmitter to standoffs in CU. Be careful not to drop Transmitter inside CU. Remove screws that secure cover and remove cover. Remove code plug from socket on PC board A2.</p>

Table 5-1. Troubleshooting Procedures - Continued

Trouble	Probable cause	Corrective action
1. (cont)	d. (cont)	<p>(4) If fuse F2 is blown, replace fuse and reconnect wires to TB7-S5 and S6.</p> <p>(5) If fuse blows, replace Data Transmitter.</p> <p>b. If voltage on TB7-S5 and S6 is good, connect positive meter lead to Data Transmitter PC board A1-E21 and negative meter lead to CU TB7-S6. Meter should indicate 20 ± 1 vdc.</p> <p>c. Connect positive meter lead to Data Transmitter PC board A2-E7 and negative meter lead to CU TB7-S6. Meter should indicate 20 ± 1 vdc.</p> <p>d. If either of these indications is incorrect, replace Data Transmitter.</p> <p>e. If these indications are correct, connect positive meter lead to Data Transmitter PC board A2-E14 and negative meter lead to TB7-S6. Meter should indicate 6.2 ± 0.4 vdc</p> <p>f. If this indication is not correct, replace Data Transmitter.</p> <p>(1) To remove Data Transmitter, tag, identify, and disconnect wires from TB6 and TB7. Remove screws that secure Data Transmitter to standoffs in CU. Be careful not to drop Transmitter inside CU. Remove screws that secure cover and remove cover. Remove code plug from its socket on PC board A2.</p> <p>(2) To replace Data Transmitter, remove screws that secure cover and remove cover from new Transmitter. Position code plug from old Transmitter over socket X1 on PC board A2. Turn</p>

Table 5-1. Troubleshooting Procedures - Continued

Trouble	Probable cause	Corrective action
1. (cont)	f. (cont)	<p>c. If meter indicates less than 0.6 vac, use oscilloscope to check clock signal on PC board A2. Remove screws that secure Data Transmitter cover and remove cover. Set oscilloscope as follows:</p> <p style="margin-left: 40px;">volts/division @ 2 v time/division @ 10ms input @dc.</p> <p>Connect scope probe to A2-TP2, red. Connect scope ground to Transmitter chassis. The scope should display clock signal as a square-wave of 6 ± 1 vdc, and 85.4 to 81.3 ms (11.7 to 12.3 Hz).</p> <div style="text-align: center;">  <p>CLOCK SIGNAL</p> <p style="margin-left: 150px;">6 ± 1 V</p> <p style="margin-left: 100px;">81.3 TO 85.4 MS (11.7 to 12.3 Hz)</p> </div> <p>d. If this indication is not correct, replace Data Transmitter.</p> <p>e. If clock signal is good use oscilloscope to check FSK signal on PC board A1. Turn off switch S1 on power supply and remove screws securing Data Transmitter to stand-offs in CU. Carefully move Data Transmitter so that test points on PC board A1 can be reached. Turn on switch S1. Set oscilloscope as follows:</p> <p style="margin-left: 40px;">volts/division @ 2 v time/division @ 0.1ms input @dc.</p> <p>Connect scope probe to A1-TP7 (violet) and scope ground to Transmitter chassis. Ground A1-TP5, green, by connecting a jumper</p>

Table 5-1. Troubleshooting Procedures - Continued

Trouble	Probable cause	Corrective action
1. (cont)	f. (cont)	<p>from A1-TP5 to Transmitter chassis. The scope should display FSK signal as a squarewave of 6 ± 1 vdc, and 0.81 to 0.76 ms (1231.9 to 1308.1 Hz).</p>  <p style="text-align: center;">CAUTION</p> <p>Do NOT short A1-E14 to chassis/ground or equipment will be damaged.</p> <p>f. Disconnect jumper from A1-TP5 and chassis. Connect jumper to A1-E14 and A1-TP5. The scope should display FSK signal as a squarewave of 6 ± 1 vdc, and 0.96 to 0.91 ms (1037.9 to 1102.1 Hz).</p>  <p>g. If either of these FSK signals is incorrect, replace Data Transmitter.</p> <p>(1) To remove Data Transmitter, tag, identify, and disconnect wires from TB6 and TB7. Remove screws that secure Data Transmitter to standoffs in CU. Be careful not to drop Transmitter inside CU. Remove screws that secure cover and remove cover. Remove code plug from its socket on PC board A2.</p>

Table 5-1. Troubleshooting Procedures - Continued

Trouble	Probable cause	Corrective action
1. (cont)	g. (cont)	<p>h. If this indication is not correct, replace Data Transmitter.</p> <p>i. Connect meter leads between terminal E27 and ground (aluminum baseplate). Meter should indicate over 100,000 ohms.</p> <p>j. If this indication is not correct, replace Data Transmitter.</p> <p>k. Connect negative meter lead to post terminal E25 and positive lead to E24. Meter should indicate 500 to 6,500 ohms. Reverse leads. Connect negative meter lead to E24 and positive lead to E25. Meter should indicate 5,000 to 65,000 ohms.</p> <p>l. If either of these indications is not correct, replace Data Transmitter.</p> <p>m. Connect negative meter lead to post terminal E28 and positive meter lead to E24. Meter should indicate 500 to 6,500 ohms. Reverse leads. Connect negative meter lead to E24 and positive lead to E28. Meter should indicate 5,000 to 65,000 ohms.</p> <p>n. If either of these indications is not correct, replace Data Transmitter.</p> <p>o. Connect negative meter lead to post terminal E29 and positive meter lead to E32. Meter should indicate 500 to 6,500 ohms. Reverse leads. Connect negative meter lead to E32 and positive lead to E29. Meter should indicate 5,000 to 65,000 ohms.</p> <p>p. If either of these indications is not correct, replace Data Transmitter.</p> <p>q. Connect negative meter lead to post terminal E30 and positive meter lead to E32. Meter should</p>

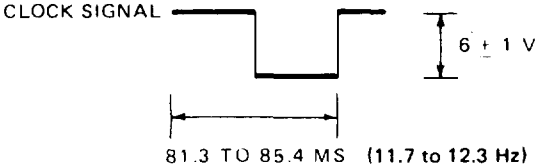
Table 5-1. Troubleshooting Procedures - Continued

Trouble	Probable cause	Corrective action
1. (cont)	h. (cont)	<p>Remove screws that secure cover. Remove captive screws and remove Receiver cover. Plug Data Receiver into status monitor module and temporarily secure with string and tape. Ensure that test points on bottom edge of PC boards are not covered. Replace status monitor module in swing-out rack and secure with screws. Turn on switch S1 on power supply. Wait one or two minutes for system to stabilize; then push RESYNC button in CU.</p> <p>a. At rear of Data Receiver, check line fault indicator (LFI) LED. If LFI is lighted, push RESET LFI switch next to it. If LFI does not go out, press RESYNC switch in CU.</p> <p>b. If LFI does not go out, use oscilloscope to check clock signal on PC board A2. Set oscilloscope as follows:</p> <p style="margin-left: 40px;">volts/division @ 2 v time/division @ 10ms input @dc</p> <p>Connect scope probe to A2-TP6 (blue) and scope ground to A4-TP3 (orange). The scope should display clock signal as a squarewave of 6.8 ± 0.4 vdc, and 85.4 to 81.3 ms (11.7 to 12.3 Hz).</p> <div style="text-align: center;">  <p>CLOCK SIGNAL</p> <p style="margin-left: 150px;">$6 \pm 1.5 \text{ V}$</p> <p style="margin-left: 100px;">81.3 TO 85.4 MS (11.7 to 12.3 Hz)</p> </div>

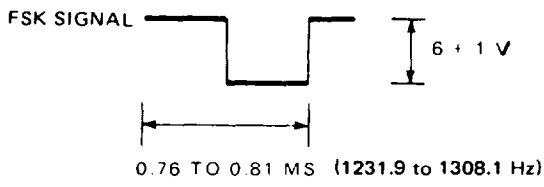
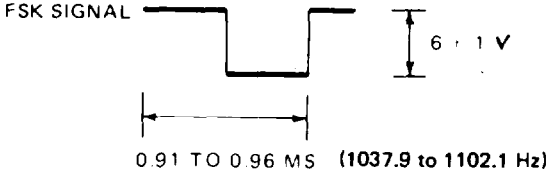
Table 5-1. Troubleshooting Procedures - Continued

Trouble	Probable cause	Corrective action
1. (cont)	h. (cont)	<p>c. If this indication is not correct, replace Data Receiver.</p> <p>d. If clock signal is good, use oscilloscope to check FSK signal on Data Receiver PC board A4. Set oscilloscope as follows:</p> <p style="margin-left: 40px;">volts/division @ 2 v time/division @ 0.1 ms input @ ac</p> <p>At the receiver connect scope probe to A4-TP6 (blue) and scope ground to A4-TP3 (orange). At the transmitter, ground A1-TP5 (green) by connecting a jumper from A1-TP5 to transmitter chassis. The scope should display FSK signal as a sine wave of 9 ± 0.5 vac, and 0.81 to 0.76 ms (1231.9 to 1308.1 Hz).</p> <div style="text-align: center;">  </div> <p>e. Set multimeter to dc volts and connect positive lead to A4-TP7 (violet), and negative meter lead to A4-TP3 (orange). Meter should indicate 9 ± 2 vdc.</p> <p style="text-align: center;">CAUTION</p> <p>Do NOT short A1-E14 to chassis/ground or equipment will be damaged.</p>

Table 5-1. Troubleshooting Procedures - Continued

Trouble	Probable cause	Corrective action
1. (cont)	h. (cont)	<p>f. At the Data Transmitter, disconnect jumper from A1-TP5 to chassis. Connect jumper from A1-TP5 to A1-E14. Change oscilloscope settings as follows:</p> <p style="margin-left: 40px;">volts/division @ 1.v time/division @ 0.5ms input @ac</p> <p>At Data Receiver, oscilloscope should be connected to A4-TP6 and TP3. The oscilloscope should display FSK signal as a sine wave of 2 ± 0.4 v and 0.91 to 0.96 ms (1037.9 to 1102.1 Hz).</p> <div style="text-align: center;">  <p>FSK SIGNAL</p> <p style="margin-left: 100px;">$2 \pm 0.4V$</p> <p style="margin-left: 100px;">0.91 TO 0.96 MS (1037.9 to 1102.1 Hz)</p> </div> <p>g. The multimeter, still connected to A4-TP7 and TP3, should indicate less than 1 vdc.</p> <p>h. If any of these scope or meter indications of the FSK signal are incorrect, replace Data Receiver.</p> <p>i. Remove all test leads and test equipment from Data Transmitter and Data Receiver.</p> <p>(1) To remove Data Receiver, turn off switch S1 on power supply. Remove screws that secure Status Monitor Module to rack and remove module through front of rack. Remove tape or string and remove Data Receiver from bottom of module. Remove code plug from its socket on PC board A1.</p>

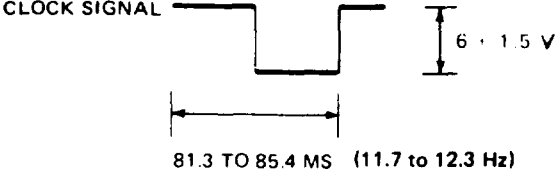
Table 5-1. Troubleshooting Procedures - Continued

Trouble	Probable cause	Corrective action
1. (cont)	h. (cont)	<p>(2) To replace Data Receiver, remove screws that secure cover and remove cover from new Receiver. Position code plug from old Receiver over socket X1 on PC board A1. Turn code plug so that painted dot or notched corner on plug lines up with dot on PC board. Carefully push plug into socket. Replace cover and secure Plug Receiver into status monitor module. Tighten captive screws to secure Receiver to status monitor module. Replace status monitor module in swingout rack and secure with screws. Turn on switch S1 on power supply. Wait one or two minutes for system to stabilize; then push RESYNC button in CU.</p> <p>j. If all FSK indications are correct and LFI is still lighted, press RESET switch. If LFI does not go out, press RESYNC switch in CU.</p> <p>k. If LFI does not go out, turn off switch S1 on Monitor Cabinet power supply. Remove screws that secure status monitor module to rack. Remove module through front of rack. Remove Receiver from status monitor module. Set multimeter to ohms and connect leads to terminals on RESET switch (S1). Press RESET switch. Meter should indicate less than one ohm.</p> <p>l. Release RESET switch. Meter should indicate 400 to 100,000 ohms.</p> <p>m. If either of these indications is not correct, replace Data Receiver.</p>

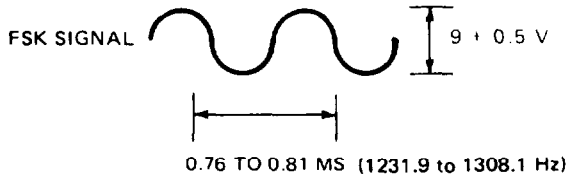
Table 5-1. Troubleshooting Procedures - Continued

Trouble	Probable cause	Corrective action
1. (cont)	h. (cont)	<p>(1) Remove code plug from its socket on PC board A1.</p> <p>(2) To replace Data Receiver, remove screws that secure cover and remove cover from new Receiver. Position code plug from old Receiver over socket X1 on PC board A1. Turn code plug so that painted dot or notched corner on plug lines up with dot on PC board. Carefully push plug into socket. Replace cover and secure with screws. Plug Receiver into status monitor module. Tighten captive screws to secure Receiver to status monitor module. Replace status monitor module in swingout rack and secure with screws. Turn on switch S1 on power supply. Wait one or two minutes for system to stabilize; then push RESYNC button in CU.</p>
2. Frequent false alarms.	a. Poor wire connections.	<p>a. Inspect all terminal points for interconnecting wires. Check Data Transmitter wires connected to TB6 and TB7 in CU. Check transmission line connections to TB1-1 and 2 on Data Transmitter. Check transmission line connections in Monitor Cabinets:</p> <p>1-zone TBB-A and A, 5-zone TBF-A and A, or B and B, or C and C, or D and D, or E and E, 25-zone TBDD-A and A, or B and B, or C and C, or D and D, or E and E; TBEE-A and A, or B and B, or C and C, or D and D, or E and E; TBFF-A and A, or B and B, or C and C, or D and D, or E and E; TBGG-A and A, or B and B, or C and C, or D and D, or E and E; TBHH-A and A, or B and B, or C and C, or D and D, or E and E.</p>

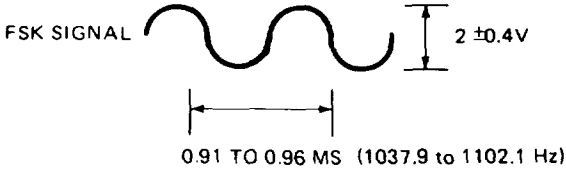
Table 5-1. Troubleshooting Procedures - Continued

Trouble	Probable cause	Corrective action
2. (cont)	c. (cont)	<p>and remove Data Receiver from bottom of module. Remove screws that secure cover. Remove captive screws and remove Receiver cover. Plug Data Receiver into status monitor module and temporarily secure with string or tape. Ensure that test points on bottom edge of PC boards are not covered. Replace status monitor module in swingout rack and secure with screws. Turn on switch S1 on power supply. Wait one or two minutes for system to stabilize; then push RESET button in CU.</p> <p>a. Set multimeter to dc volts and connect positive meter lead to Data Receiver PC board A4-TP4, yellow, and negative meter lead to A4-TP3, orange. Meter should indicate 20 ± 1 vdc. Maintain this check for a period of time to ensure that voltage is stable.</p> <p>b. Connect positive meter lead to A4-TP2, red and negative meter lead to A4-TP3, orange. Meter should indicate 6.8 ± 0.4 vdc. Maintain this check for a period of time to ensure that voltage is stable.</p> <p>c. If voltage changes during either of these checks, replace Data Receiver.</p> <p>(1) To remove Data Receiver remove captive screws that secure Data Receiver to Status Monitor.</p> <p>(2) Remove code plug from its socket on PC board A1.</p> <p>(3) To replace Data Receiver, remove screws that secure cover and remove captive screws. Remove cover from new Receiver. Position code plug from old Receiver over socket X1 on PC board A1.</p>

Table 5-1. Troubleshooting Procedures - Continued

Trouble	Probable cause	Corrective action						
2. (cont)	d. (cont)	<p>b. If clock signal is stable, check FSK signal. Set oscilloscope as follows:</p> <table style="margin-left: 40px;"> <tr> <td>volts/division</td> <td>@ 2 v</td> </tr> <tr> <td>time/division</td> <td>@ 0.1 ms</td> </tr> <tr> <td>input</td> <td>@ dc</td> </tr> </table> <p>Connect scope probe to A1-TP7, violet. Connect scope ground to Transmitter chassis. Ground A1-TP5 (green) by connecting a jumper from A1-TP5 to Transmitter chassis. The scope should display FSK signal as a squarewave of 6 ± 1 vdc, and 0.81 to 0.76 ms (1231.9 to 1308.1 Hz). Maintain this check for a period of time to ensure that FSK signal is stable.</p> <p style="text-align: center;">CAUTION</p> <p>Do NOT short A1-E14 to chassis/ground or equipment will be damaged.</p> <p>c. Disconnect jumper (between A1-TP5 and chassis) from Transmitter chassis and connect it to A1-E14. The scope should display FSK signal as a squarewave of 6 ± 1 vdc, and 0.96 to 0.91 ms (1037.9 to 1102.1 Hz). Maintain this check for a period of time to ensure that FSK signal is stable.</p> <p>d. if either clock signal or FSK signal changes, replace Data Transmitter.</p> <p>(1) To remove Data Transmitter disconnect wires from TB6 and TB7. Remove screws that secure Data Transmitter to standoffs in CU. Be careful not to drop Transmitter inside CU. Remove code plug from its socket on PC board A2.</p>	volts/division	@ 2 v	time/division	@ 0.1 ms	input	@ dc
volts/division	@ 2 v							
time/division	@ 0.1 ms							
input	@ dc							

Table 5-1. Troubleshooting Procedures - Continued

Trouble	Probable cause	Corrective action
2. (cont)	e. (cont)	<p>volts/division @ 2 v time/division @ 10ms input @ dc</p> <p>Connect scope probe to A2-TP6, blue. Connect scope ground to A4-TP3, orange. The scope should display clock signal as a squarewave of 6.8 ± 0.4 vdc, and 81.3 to 85.4 ms (11.7 to 12.3 Hz). Maintain this check for a period of time to ensure that clock is stable.</p> <div style="text-align: center;">  <p>CLOCK SIGNAL</p> <p style="text-align: right;">6 ± 1 V</p> <p style="text-align: center;">81.3 TO 85.4 MS (11.7 to 12.3 Hz)</p> </div> <p>b. If clock signal is good, use oscilloscope to check FSK signal on Data Receiver PC board A4. Set oscilloscope as follows:</p> <p>volts/division @ 2 v time/division @ 0.1 ms input @ ac</p> <p>At the Receiver connect scope probe to A4-TP6, blue. Connect scope ground to A4-TP3, orange. At the transmitter, ground A1-TP5 (green) by connecting a jumper from A1-TP5 to transmitter chassis. The scope should display FSK signal as a sine wave of 9 ± 0.5 vac, and 0.81 to 0.76 ms (1231.9 to 1308.1 Hz). Maintain this check for a period of time to ensure that FSK signal is stable.</p>

Table 5-1. Troubleshooting Procedures - Continued

Trouble	Probable cause	Corrective action						
2. (cont)	e. (cont)	<div data-bbox="842 425 1404 606" data-label="Figure"> <p>FSK SIGNAL</p> <p>9 ± 0.5 V</p> <p>0.76 TO 0.81 MS (1231.9 to 1308.1 Hz)</p> </div> <p data-bbox="859 723 1371 946">c. Set multimeter to dc volts and connect positive meter lead to A4-TP7 (violet), and negative meter lead to A4-TP3 (orange). Meter should indicate 9 ±2 vdc. Maintain this check for a period of time to ensure that voltage is stable.</p> <p data-bbox="1049 968 1197 1010">CAUTION</p> <p data-bbox="892 1042 1379 1106">Do NOT short A1-E14 to chassis/ground or equipment will be damaged.</p> <p data-bbox="859 1138 1354 1287">d. At the Data Transmitter, disconnect jumper from A1-TP5 to chassis. Connect jumper from A1-TP5 to A1-E14. Change oscilloscope settings as follows:</p> <table data-bbox="925 1319 1305 1425"> <tr> <td>volts/division</td> <td>@ 1. v</td> </tr> <tr> <td>time/division</td> <td>@ 0.5 ms</td> </tr> <tr> <td>input</td> <td>@ ac</td> </tr> </table> <p data-bbox="925 1457 1354 1713">At Data Receiver, oscilloscope should be connected to A4-TP6 and TP3. The oscilloscope should display FSK signal as a sine wave of 2 ±0.4 v and 0.91 to 0.96 ms (1037.9 to 1102.1 Hz). Maintain this check for a period of time to ensure that FSK signal is stable.</p>	volts/division	@ 1. v	time/division	@ 0.5 ms	input	@ ac
volts/division	@ 1. v							
time/division	@ 0.5 ms							
input	@ ac							

Table 5-1. Troubleshooting Procedures - Continued

Trouble	Probable cause	Corrective action
2. (cont)	e. (cont)	<div style="text-align: center;"> <p>FSK SIGNAL 2 ± 0.4V</p> <p style="text-align: center;">0.91 TO 0.96 MS (1037.9 to 1102.1 Hz)</p> </div> <p>e. The multimeter, still connected to A4-TP7 and TP3, should indicate less than 1 vdc. Maintain this check for a period of time to ensure that this voltage is stable.</p> <p>f. If the clock, or FSK signal, or voltage changes, replace Data Receiver.</p> <p>(1) To remove Data Receiver, turn off switch S1 on power supply. Remove screws that secure status monitor module to rack and remove module through front of rack. Remove string or tape and loosen captive screws and remove Data Receiver from bottom of module. Remove code plug from its socket on PC board A1.</p> <p>(2) To replace Data Receiver, remove screws that secure cover and remove cover from new Receiver. Position code plug from old Receiver over socket X1 on PC board A1. Turn code plug so that painted dot or notched corner on plug lines up with dot on PC board. Carefully push plug into socket. Replace cover and secure with screws. Plug Receiver into status monitor module. Tighten four captive screws to secure Receiver to status monitor module. Replace status monitor module in swingout rack and secure with screws. Turn on switch S1 on power supply. Wait one or two minutes for system to stabilize; then push RESYNC button in CU. Remove all test leads and test equipment from Data Transmitter and Data Receiver.</p>

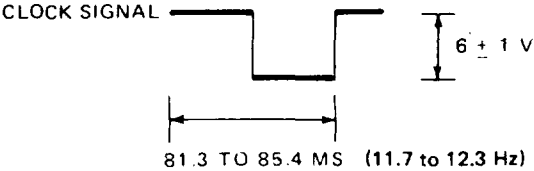
- d. To replace Data Receiver, plug Receiver into bottom of status monitor module. Tighten captive screws to secure Receiver to module. Replace status monitor module in swingout rack and secure with screws. Secure swingout rack. Turn on switch S1 on power supply.

NOTE

Code plugs in Data Transmitter and Data Receiver must have matching serial numbers or system will not operate properly. Therefore, code plugs must be replaced in pairs.

- e. To remove code plug from Data Receiver, unlock and open Monitor Cabinet, and turn off switch S1 on power supply. Release swingout rack. Remove screws that secure status monitor module to rack and remove module through front of rack. Loosen captive screws and remove Data Receiver from bottom of module. Remove screws that secure cover, and remove cover. Remove the code plug from its socket on PC board A1.
- f. To replace code plug in Data Receiver, position plug over socket X1 on PC board A1. Turn plug so pointed dot or notched corner on plug lines up with dot on PC board. Carefully push plug into socket. Replace cover and secure with screws. Plug Data Receiver into bottom of status monitor module. Tighten captive screws to secure Receiver to module. Replace status monitor module in swingout rack and secure with screws. Secure swingout rack. Turn on switch S1 on power supply.
- g. To remove code plug from Data Transmitter, unlock and open CU. Remove screws that secure Transmitter cover to baseplate and remove cover. Remove code plug from socket on PC board A2.
- h. To replace code plug in Data Transmitter, position plug over socket X1 on PC board AZ. Turn plug so painted dot

or notched corner on the plug lines up with dot on the PC board. Carefully push plug into socket. Replace cover and secure with screws.

- i. To remove interconnecting wires (600-ohm twisted pair), disconnect wires from TB-1 and 2 in Data Transmitter. Tag and disconnect wires from terminals in Monitor Cabinet. Check interconnecting wiring diagram for terminals in Monitor Cabinet.
- j. To replace interconnecting wiring (600-ohm twisted pair), install wires per steps in TM 5-6350-264-14/1 System Manual. Connect wires to TB1-1 and 2 on Data Transmitter baseplate. Check interconnecting wiring diagram for terminals in Monitor Cabinet. The wiring diagram is stored inside the Control Unit door.
- k. After replacement of major components or assemblies, test the DTS for proper operation as follows:
 - (1) Turn mode switch on CU to ACCESS, open CU door, and pull Tamper Alarm Switch (TAS) plunger all the way out. Turn mode switch to TEST/RESET and then to SECURE. Monitor Cabinet should indicate a secure condition.
 - (2) If an Ultrasonic Motion Sensor (UMS) is installed near the CU, ensure that it does not cause an alarm to be activated when a secure condition is desired. Create an alarm condition (by activating a nearby sensor). After expiration of the time delay period, the Monitor Cabinet should indicate an alarm condition.
 - (3) Remove cause of alarm, turn mode switch to TEST/RESET and then to SECURE. At the Monitor Cabinet, go to the Status Monitor Module with alarm lights flashing and move reset switch to ACK and then to RESET. Monitor Cabinet should indicate a secure condition.

- (4) Turn mode switch to ACCESS. Monitor Cabinet should indicate an access condition.
- (5) Remove ac power fuse F1 from CU power supply. AC POWER indicator lights on Monitor Cabinet should change from on-steady to flashing, and the audible signal device should sound.
- (6) Move reset switch on Status Monitor Module to ACK. Indicator lights should go out and audible signal device should be silenced.
- (7) Reinstall ac power fuse F1 in CU power supply. AC POWER indica-

tor lights should flash and the audible signal device should sound.

- (8) Move reset switch on Status Monitor Module to ACK. AC POWER indicator lights should change from flashing to on steady and the audible signal device should be silenced.

NOTE

Code plugs cannot be tested. If you suspect a bad code plug, install two new plugs with matching serial numbers. Bad or mismatched code plugs will most probably result in continuously changing status indications at the Monitor Cabinet.

CHAPTER 6

REPAIR OF THE DATA TRANSMITTER AND DATA RECEIVER

This chapter is not applicable to this equipment.

APPENDIX A

REFERENCES

1. DEMOLITION
TM 750-244-3
Procedures for Destruction of Equipment
to Prevent Enemy Use
2. FIRE PROTECTION
TB5-4200-200-10
Hand Portable Fire Extinguishers
Approved for Army Users
3. MAINTENANCE
DA PAM 738-750
The Army Maintenance
Management System
4. TRI-SERVICE MANUALS

DMWR 5-6350-264
NAVELEX EE181-AA-MMD-010/E121
J-SIIDS MWR
AIR FORCE T.O. 31S9-4-1-213
Depot Maintenance Work Requirement

TM 5-6350-264-14-1
NAVELEX EE181-AA-INM-020/E121
J-SIIDS INS
AIR FORCE T.O. 31S9-4-1-201
Installation, Operation and Checkout
Procedures

TM 5-6350-264-14&P-2
NAVELEX EE181-AA-OMI-030/E121
RT1161 M9443
AIR FORCE T.O. 31S9-2FSS9-1-2
Transceiver, Ultrasonic Signal and Pro-
cessor, Ultrasonic Motion Signal

TM 5-6350-264-14&P-3
NAVELEX EE181-AA-OMI-040/E121
R1860 M9443
AIR FORCE T.O. 31S9-2FSS9-1-3
Receiver Passive Signal, Ultrasonic and
Processor, Passive Signal, Ultrasonic

TM 5-6350-264-14&P-4
NAVELEX EE181-AA-OMI-050/E121
DT546 M9442
AIR FORCE T.O. 31S9-2FSS9-1-4
Detector, Vibration Signal and Processor,
Vibration Signal

TM 5-6350-264-14&P-S
NAVELEX EE181-AA-OMI-060/E121
SA-1955
AIR FORCE T.O. 31S9-2FSS9-1-5
Switch, Balanced Magnetic

TM 5-6350-264-14&P-6
NAVELEX EE181-AA-OMI-070/E121
DT-545
AIR FORCE T.O. 31S9-2FSS9-1-6
Sensor, Grid Wire

TM 5-6350-264-14&P-7
NAVELEX EE181-AA-OMI-080/E121
DT-548
AIR FORCE T.O. 31S9-2FSS9-1-7
Sensor, Capacity Proximity

TM 5-6350-264-14&P-12

NAVELEX EE 181-AA-OMI-13A/E121 R1861-T1257

TO 31S9-2FSS9-1-12

TM 5-6350-264-14&P-8 NAVELEX EE181-AA-OMI-090/E121 SA-1954 AIR FORCE T.O. 31S9-2FSS9-1-8	Switch, Alarm Latching
TM 5-6350-264-14&P-9 NAVELEX EE181-AA-OMI-100/E121 DZ-204 AIR FORCE T.O. 31S9-2FSS9-1-9	Alarm, Audible
TM 5-6350-264-14&P-10 NAVELEX EE181-AA-OMI-110/E121 C-9412 AIR FORCE T.O. 31S9-2FSS9-1-10	Control Unit, Alarm Set
TM 5-6350-264-14&P-11 NAVELEX EE181-AA-OMI-120/E121 C-7359-60-1 AIR FORCE T.O. 31S9-2FSS9-1-11	Cabinet, Monitor, Type A, Type B, Type C and Monitor Module, Status, Monitor Module, Alarm
TM 5-6350-264-14&P-12 NAVELEX EE181-AA-OMI-130/E121 R1861-T1257 AIR FORCE T.O. 31S9-2FSS9-1-12	Receiver, Data and Transmitter, Data
TM 5-6350-264-14&P-13 NAVELEX EE181-AA-OMI-140/E121 DT-547 AIR FORCE T.O. 31S9-2FSS9-1-13	Sensor, Magnetic Weapons (DT-547)
TE 5-6350-264 NAVELEX EE181-AB-OMI-010/E121 J-SIIDS AIR FORCE T.O. 31S9-4-1-111	Selection and Application of Joint Services Interior Intrusion Detection System

- | | |
|--|---|
| 5. PAINTING
SB 11-573 | Painting and Preservation Supplies
Available for Field Use for Electronic
Equipment |
| TM 43-0139 | Painting Instructions for Field Use |
| 6. RADIOACTIVE MATERIAL
TB 43-0141 | Instructions for Safe Handling, Maintenance,
Storage, and Disposal of Radioactive
Commodities |
| 7. SHIPMENT AND STORAGE
TM 740-90-1 | Administrative Storage of Equipment |

APPENDIX B

MAINTENANCE ALLOCATION CHART

Section I. INTRODUCTION

B-1. GENERAL.

a. This section provides a general explanation of all maintenance and repair functions authorized at various maintenance levels.

b. Section II designates overall responsibility for the performance of maintenance functions on the identified end item or component. The implementation of the maintenance functions upon the end item or component will be consistent with the assigned maintenance functions.

c. Section III lists the special tools and test equipment required for each maintenance function as referenced from section II.

d. Section IV contains supplemental instructions or explanatory notes for a particular maintenance function. (Not Applicable)

B-2. MAINTENANCE FUNCTIONS. Maintenance functions are defined as follows:

a. Inspect. To determine the serviceability of an item by comparing its physical, mechanical and/or electrical characteristics with established standards through examination.

b. Test. To verify serviceability and detect incipient failure by measuring the mechanical or electrical characteristics of an item and comparing those characteristics with prescribed standards.

c. Service. Operations required periodically to keep an item in proper operating condition, i.e., to clean, to preserve, to drain, to paint, or to replenish fuel, lubricants, hydraulic fluids, or compressed air supplies.

d. Adjust. To maintain, within prescribed limits, by bringing into proper or exact position, or by setting the operating characteristics to specified parameters.

e. Align. To adjust specified variable elements of an item to bring about optimum or desired performance.

f. Calibrate. To determine and cause corrections to be made, or to be adjusted on instruments for test, measuring and diagnostic equipments used in precision measurement. Consists of comparisons of two instruments, one of which is a certified standard of known accuracy, to detect and adjust any discrepancy in the accuracy of the instrument being compared.

g. Install. The act of emplacing, seating, or fixing into position an item, part, or module in a manner to allow the proper functioning of an equipment or system.

h. Replace. The act of substituting a serviceable like part, subassembly or module for an unserviceable counterpart.

i. Repair. The application of maintenance services (inspect, test, service, adjust, align, calibrate, or replace) or other maintenance actions (welding, grinding, riveting, straightening, facing, remachining, or resurfacing) to restore serviceability to an item by correcting specific damage, fault, malfunction, or failure in a part, subassembly, module, end item or system.

j. Overhaul. That maintenance effort (service/actions) necessary to restore an item to a completely serviceable/operational condition as prescribed by maintenance standards (i.e., DMWR) in appropriate technical publications. Overhaul is normally the highest degree of maintenance performed by the Army. Overhaul does not normally return an item to like new condition.

k. Rebuild. Consists of those services/actions necessary for the restoration of unserviceable equipment to a like new condition in accordance with original manufacturing standards. Rebuild is the highest degree of materiel maintenance applied to

Army equipment. The rebuild operation includes the act of returning to zero those age measurements (hours/miles, etc.) considered in classifying Army equipments/components.

B-3. COLUMN ENTRIES.

a. Column 1, Group Number. Column 1 lists group numbers, the purpose of which is to identify components, assemblies, subassemblies, and modules with the next higher assembly.

b. Column 2, Component/Assembly. Column 2 contains the names of components, assemblies, subassemblies, and modules for which maintenance is authorized.

c. Column 3, Maintenance Function. Column 3 lists the functions to be performed on the item listed in column 2.

d. Column 4, Maintenance Level. Column 4 specifies, by the listing of a “work time” figure in the appropriate subcolumn(s), the lowest level of maintenance authorized to perform the function listed in column 3. This figure represents the active time required to perform the maintenance function at the indicated level of maintenance. If the number or complexity of the tasks within the listed maintenance function varies at different maintenance levels, appropriate “work time” fig-

ures will be shown for each level. The number of man-hours specified by the “work time” figure represents the average time required to restore an item (assembly, subassembly, component, module, end item, or system) to a serviceable condition under typical field operating conditions. This time includes preparation time, troubleshooting time, and quality assurance/quality control time in addition to the time required to perform the specific tasks identified for the maintenance functions authorized in the maintenance allocation chart. The symbol designations for the various maintenance levels are as follows:

- C Operator or crew
- O Organization maintenance
- F Direct support maintenance
- H General support maintenance
- D Depot maintenance

e. Column 5, Tools and Equipment. Column 5 specifies, by code, those common tool sets (not individual tools) and special tools, test, and support equipment required to perform the designated function.

f. Column 6, Remarks. Column 6 contains an alphabetic code which leads to the remark in section IV, Remarks, which is pertinent to the item opposite the particular code.

Section II. MAINTENANCE ALLOCATION CHART

for

Data Receiver (R-1861) and Data Transmitter (T-1257)

(1) Group number	(2) Component/ assembly	(3) Maintenance function	(4) Maintenance level					(5) Tools and equipment	(6) Remarks
			C	O	F	H	D		
01	Data Receiver	Test Replace			1.5 0.3				
	Code Plug	Replace			0.5				*
02	Data Trans- mitter	Test Replace			1.5 0.3				
	Code Plug	Replace			0.5				*

*Testing of code plugs at direct support maintenance is limited to substitution with a matched pair of plugs known to be serviceable.

Section III. TOOL AND TEST EQUIPMENT REQUIREMENTS

for

Data Receiver (R-1861) and Data Transmitter (T-1257)

(1) Reference	(2) Maintenance category	(3) Nomenclature	(4) National stock number (NSN)	(5) Tool number

Section IV. REMARKS

Maintenance Allocation Chart

Reference code	Remarks
A	Testing of code plugs at Direct Support Maintenance level is limited to substitution with a known serviceable plug.

APPENDIX C

ORGANIZATIONAL, DIRECT SUPPORT, AND GENERAL SUPPORT MAINTENANCE REPAIR PARTS AND SPECIAL TOOLS LIST

Section I. INTRODUCTION

1. SCOPE. This RPSTL lists and authorizes spares and repair parts; special test, measurement, and diagnostic equipment (TMDE); and other special support equipment required for performance of organizational, direct support and general support, of the Data Receiver and Data Transmitter. It authorizes the requisitioning, issue, and disposition of spares, repair parts and special tools as indicated by the source, maintenance and recoverability (SMR) codes.

2. GENERAL. In addition to this section, Introduction, this Repair Parts and Special Tools List is divided into the following sections:

a. Section II. Repair Parts List. A list of spares and repair parts authorized by this RPSTL for use in the performance of maintenance. The list also includes parts which must be removed for replacement of the authorized parts. Parts lists are composed of functional groups in ascending alphanumeric sequence, with the parts in each group listed in ascending figure and item number sequence. Bulk materials are listed in item name sequence. Repair parts kits are listed separately in their own functional group within Section II. Repair parts for repairable special tools are also listed in this section. Items listed are shown on the associated illustration(s)/figure(s).

b. Section III. Special Tools List. A list of special tools, special TMDE, and other special support equipment authorized by this RPSTL (as indicated by Basis of Issue (BOI) information in DESCRIPTION AND USABLE ON CODE column) for the performance of maintenance.

c. Section IV. National Stock Number and Part Number Index. A list, in National item identification number (NIIN) sequence, of all National stock numbered items appearing in the listing, followed by a list in alphanumeric sequence of all part numbers appearing in the listings. National stock numbers and part numbers are cross-referenced to each illustration figure and item number appearance.

3. EXPLANATION OF COLUMNS (SECTIONS II AND III).

a. ITEM NO. (Column (1)). Indicates the number used to identify items called out in the illustration.

b. SMR Code (Column (2)). The Source, Maintenance, and Recoverability (SMR) code is a 5-position code containing supply/requisitioning information, maintenance category authorization criteria, and disposition instruction, as shown in the following breakout:

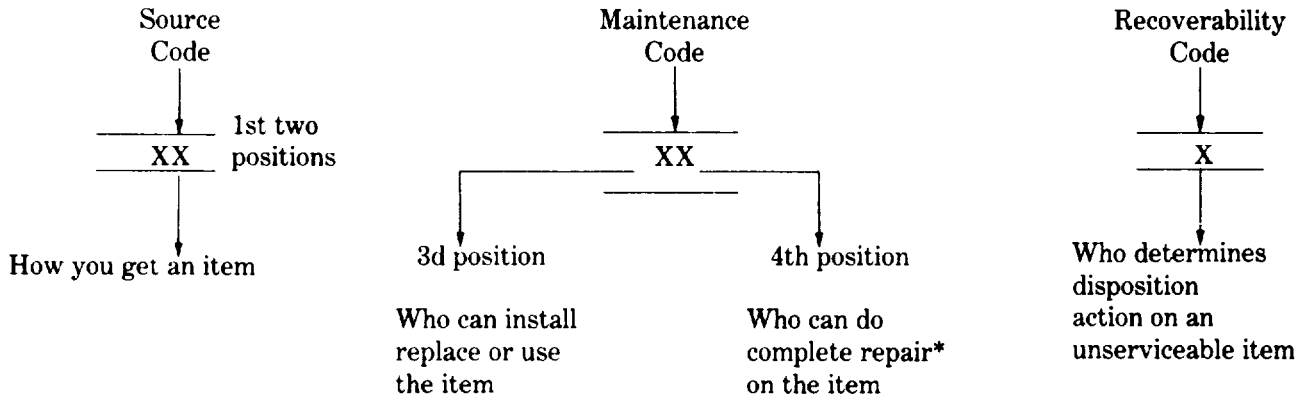

*Complete Repair: Maintenance capacity, capability, and authority to perform all corrective maintenance tasks of the "Repair" function in a use/user environment in order to restore serviceability to a failed item.

(1) **Source Code.** The source code tells you how to get an item needed for maintenance, repair, or overhaul of an end/equipment. Explanations of source codes follows:

Code	Explanation
PA PB PC** PD PE PF PG	Stocked items; use the applicable NSN to request/requisition items with these source codes. They are authorized to the category indicated by the code entered in the 3d position of the SMR code. **NOTE: Items coded PC are subject to deterioration.
KD KF KB	Items with these codes are not to be requested/requisitioned individually. They are part of a kit which is authorized to the maintenance category indicated in the 3d position of the SMR code. The complete kit must be requisitioned and applied.
MO-(Made at org/ AVUM Level) MF-(Made at DS/ AVUM Level) MH-(Made at GS Level) ML-(Made at Spe- cialized Repair Activity (SRA) MD-(Made at Depot)	Explanation Items with these codes are not to be requested/requisitioned individually. They must be made from bulk material which is identified by the part number in the DESCRIPTION and USABLE ON CODE (UOC) column and listed in the Bulk Material group of the repair parts list in the RPSTL. If the item is authorized to you by the 3d position code of the SMR code, but the source code indicates it is made at a higher level, order the item from the higher level of maintenance.
AO-(Assembled by org/AVUM Level) AF-(Assembled by DS/AVIM Level) AH-(Assembled by GS Category) AL-(Assembled by SRA) AD-(Assembled by Depot)	Explanation Items with these codes are not to be requested/requisitioned individually. The parts that make up the assembled item must be requisitioned or fabricated and assembled at the level of maintenance indicated by the source code. If the 3d position code of the SMR code authorizes you to replace the item, but the source code indicates the items are assembled at a higher level, order the item from the higher level of maintenance.

Code	Explanation
XA	Do not requisition an "XA" -coded item. Order its next higher assembly. (Also, refer to the NOTE below.)
XB	If an "XB" item is not available from salvage, order it using the FSCM and part number given.
XC	Installation drawing, diagram, instruction sheet, field service drawing, that is identified by manufacturer's part number.
XD	Item is not stocked. Order an "XD" -coded item through normal supply channels using the FSCM and part number given, if no NSN is available.

NOTE

Cannibalization or controlled exchange, when authorized, may be used as a source of supply for items with the above source codes, except for those source coded "XA" or those aircraft support items restricted by requirements of AR 700-42.

(2) Maintenance Code. Maintenance codes tells you the level(s) of maintenance authorized to USE and REPAIR support items. The maintenance codes are entered in the third and fourth positions of the SMR Code as follows:

(a) The maintenance code entered in the third position tells you the lowest maintenance level authorized to remove, replace, and use an item. The maintenance code entered in the third position will indicate authorization to one of the following levels of maintenance.

Code	Application/Explanation
C	-Crew or operator maintenance done within organizational or aviation unit maintenance.
O	-Organizational or aviation unit category can remove, replace, and use the item.
F	-Direct support or aviation intermediate level can remove, replace, and use the item.
H	-General support level can remove, replace, and use the item.
L	-Specialized repair activity can remove, replace, and use the item.
D	-Depot level can remove, replace, and use the item.

(c) The maintenance code entered in the fourth position tells whether or not the item is to be repaired and identifies the lowest maintenance level with the capability to do complete repair (i.e., perform all authorized repair functions.) NOTE: Some limited repair may be done on the item at a lower level of maintenance, if authorized by the Maintenance Allocation Chart (MAC) and SMR codes. This position will contain one of the following maintenance codes.

Code	Application/Explanation
O	-Organizational or (aviation unit) is the lowest level that can do complete repair of the item.
F	-Direct support or aviation intermediate is the lowest level that can do complete repair of the item.

Code	Application/Explanation
H	-General support is the lowest level that can do complete repair of the item.
L	-Specialized repair activity is the lowest level that can do complete repair of the item.
D	-Depot is the lowest level that can do complete repair of the item.
Z	-Nonreparable. No repair is authorized.
B	-No repair is authorized. (No parts or special tools are authorized for the maintenance of a "B" coded item). However, the item may be reconditioned by adjusting, lubricating, etc., at the user level.

(3) Recoverability Code. Recoverability codes are assigned to items to indicate the disposition action on unserviceable items. The recoverability code is entered in the fifth position of the SMR Code as follows:

Recoverability Codes	Application/Explanation
Z	-Nonreparable item. When unserviceable, condemn and dispose of the item at the level of maintenance shown in 3d position of SMR Code.
O	-Reparable item. When uneconomically reparable, condemn and dispose of the item at organizational or aviation unit level.
F	-Reparable item. When uneconomically reparable, condemn and dispose of the item at the direct support or aviation intermediate level.
H	-Reparable item. When uneconomically reparable, condemn and dispose of the item at the general support level.
D	-Reparable item. When beyond lower level repair capability, return to depot. Condemnation and disposal of item not authorized below depot level.
L	-Reparable item. Condemnation and disposal not authorized below specialized repair activity (SRA).
A	-Item requires special handling or condemnation procedures because of specific reasons (e.g., precious metal content, high dollar value, critical material, or hazardous material). Refer to appropriate manuals/directives for specific instructions.

c. FSCM (Column (3)). The Federal Supply Code for Manufacturer (FSCM) is a 5-digit numeric code which is used to identify the manufacturer, distributor, or Government agency, etc., that supplies the item.

d. PART NUMBER (Column (4)). Indicates the primary number used by the manufacturer, (individual, company, firm, corporation, or Government activity), which controls the design and characteristics of the item by means of its engineering drawings, specifications standards, and inspection requirements to identify an item or range of items.

NOTE

When you use a NSN to requisition an item, the item you receive may have a different part number from the part ordered.

e. DESCRIPTION AND USABLE ON CODE (UOC) (Column (5)). This column includes the following information:

- (1) The Federal item name and, when required, a minimum description to identify the item.
- (2) The physical security classification of the item is indicated by the parenthetical entry, e.g., Phy Sec C1 - Confidential, Phy Sec C1 (S) - Secret, Phy Sec C1 (T) - Top Secret.
- (3) Items that are included in kits and sets are listed below the name of the kit or set.
- (4) Spare/repair parts that make up an assembled item are listed immediately following the assembled item line entry.
- (5) Part numbers for bulk materials are referenced in this column in the line item entry for the item to be manufactured/fabricated.
- (6) When the item is not used with all serial numbers of the same model, the effective serial numbers are shown on the last line(s) of the description (before UOC).
- (7) The usable on code, when applicable (see paragraph 5, Special Information).
- (8) In the Special Tools List section, the basis of issue (BOI) appears as the last line(s) in the entry for each special tool, special TMDE, and other special support equipment. When density of equipments supported exceeds density spread indicated in the basis of issue, the total authorization is increased proportionately.
- (9) The statement "END OF FIGURE" appears just below the last item description in Column 5 for a given figure in both Section II and Section III.

f. QTY (Column (6)). The QTY (quantity per figure column) indicates the quantity of the item used in the breakout shown on the illustration figure, which is prepared for a functional group, subfunctional group, or an assembly. A "V" appearing in this column in lieu of a quantity indicates that the quantity is variable and may vary from application to application.

4. EXPLANATION OF COLUMNS (SECTION IV).

a. NATIONAL STOCK NUMBER (NSN) INDEX.

(2) **STOCK NUMBER column.** This column lists the NSN by National item identification number

(NIIN) sequence. The NIIN consists of the last nine digits of the NSN, i.e. (5305-01-574-1467).
NSN
NIIN

When using this column to locate an item, ignore the first 4 digits of the NSN. However, the complete NSN should be used when ordering items by stock number.

(2) **FIG. column.** This column lists the number of the figure where the item is identified/located. The figures are in numerical order in Section II and Section III.

(3) **ITEM column.** The item number identifies the item associated with the figure listed in the adjacent FIG. column. This item is also identified by the NSN listed on the same line.

b. PART NUMBER INDEX. Part numbers in this index are listed by part number in ascending alphanumeric sequence (i.e., vertical arrangement of letter and number combination which places the first letter or digit of each group in order A through Z, followed by the numbers 0 through 9 and each following letter or digit in like order).

(1) **FSCM column.** The Federal Supply Code for Manufacturer (FSCM) is a 5-digit numeric code used to identify the manufacturer, distributor, or Government agency, etc., that supplies the item.

(2) **PART NUMBER column.** Indicates the primary number used by the manufacturer (individual, firm, corporation, or Government activity), which controls the design and characteristics of the item by means of its engineering drawings, specifications standards, and inspection requirements to identify an item or range of items.

(3) **STOCK NUMBER column.** This column lists the NSN for the associated part number and manufacturer identified in the PART NUMBER and FSCM columns to the left.

(4) **FIG. column.** This column lists the number of the figure where the item is identified/located in Sections II and III.

(5) **ITEM column.** The item number is that number assigned to the item as it appears in the figure referenced in adjacent figure number column.

5. SPECIAL INFORMATION

Usable On Code. The usable on code appears in the lower left corner of the Description Column heading. Usable on codes are shown as "UOC:...." in the Description Column (justified left) on the first line applicable item description/nomenclature. Uncoded items are applicable to all models. Identification of the usable on codes used in the RPSTL are:

The usable on codes used in the RPSTL are:

<u>Code</u>	<u>Used On</u>
CWS	Model R-1861
CWT	Model T-1257

6. HOW TO LOCATE REPAIR PARTS.

a. **When National Stock Number or Part Number is NOT Known.**

(2) **First.** Using the table of contents, determine the assembly group or subassembly group to which the item belongs. This is necessary since figures are prepared for assembly groups and subassembly groups, and listings are divided into the same groups.

(2) **Second.** Find the figure covering the assembly group or subassembly group to which the item belongs.

(3) **Third.** Identify the item on the figure and note the item number.

(4) **Fourth.** Refer to the Repair Parts List for the figure to find the part number for the item number noted on the figure.

(5) **Fifth.** Refer to the Part Number Index to find the NSN, if assigned.

b. When National Stock Number or Part Number is Known:

- (1) **First.** Using the Index of National Stock Numbers and Part Numbers, find the pertinent National Stock Number or Part Number. The NSN index is in National Item Identification Number (NIIN) sequence (see 4a(1)). The part numbers in the Part Number index are listed in ascending alphanumeric sequence (see paragraph 4b). Both indexes cross-reference you to the illustration figure and item number of the item you are looking for.
- (2) **Second.** After finding the figure and item number, verify that the item is the one you are looking for, then locate the item number in the repair parts list for the figure.

7. ABBREVIATIONS. Abbreviations used in this manual are listed in MIL-STD-12.

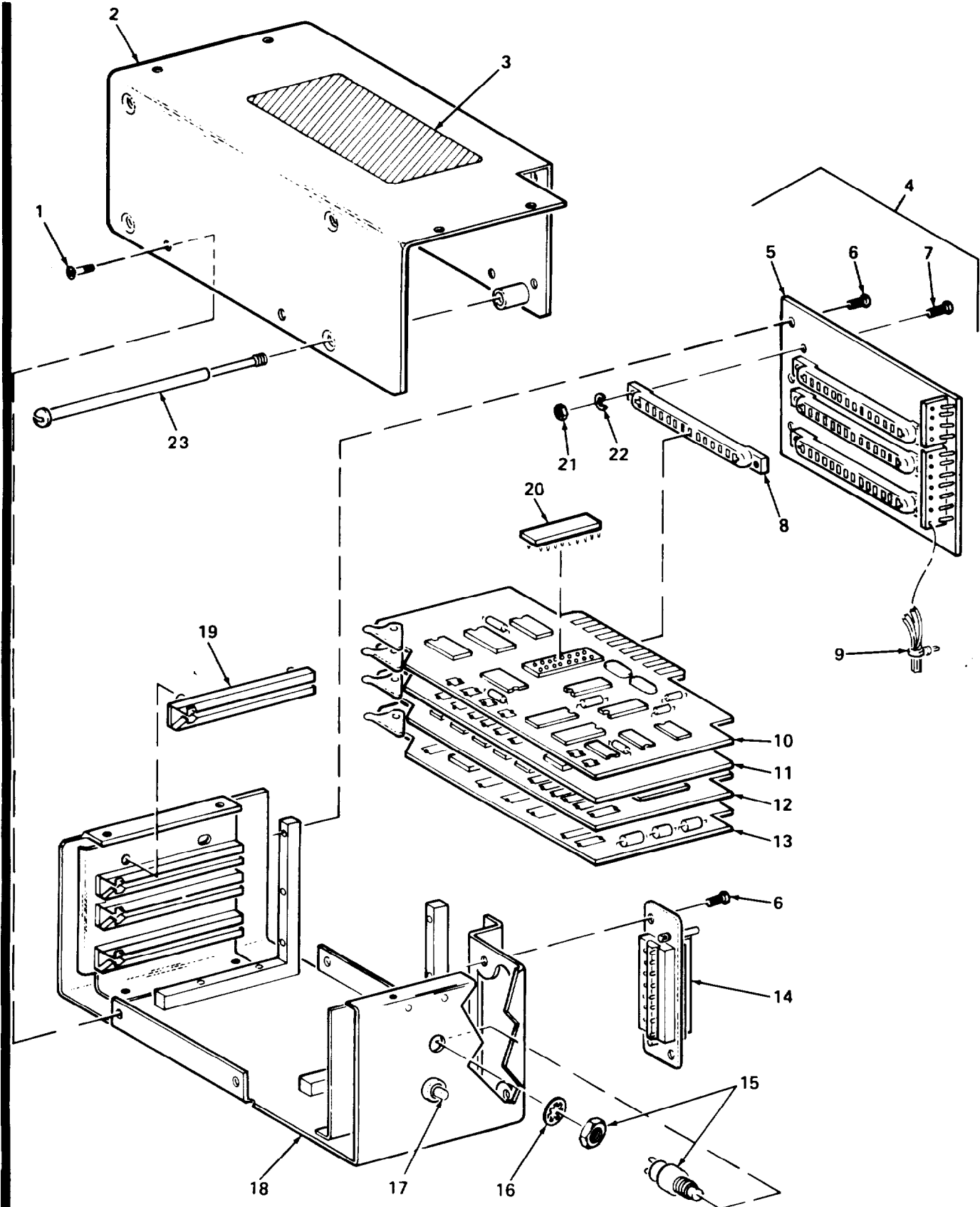

Figure 1. C-1 Data Receiver R-1861/FSS-9(V)

SECTION II

(1) ITEM NO	(2) SMR CODE	(3) FSCM	(4) PART NUMBER	(5) DESCRIPTION AND USABLE ON CODES (UOC)	(6) QTY
				GROUP 01 DATA RECEIVER	
				FIG. C-1 DATA RECEIVER R-1861/FSS-9(V)	
1	PAFZZ	96906	MS35190-221	SCREW	10
2	XBFZZ	97403	13220E3502	COVER, DATA RECEIVER	1
3	XBFZZ	97403	13220E3536	PLATE, IDENTIFICATION	1
4	XAFZZ	97403	13220E3503-1	INTERCONNECTING SUBASSY	1
5	XAFZZ	97403	13220E3504	.PRINTED WIRING BOARD, INTERCONNECT ASSSY	1
6	XAFZZ	96906	MS35206-213	.SCREW	8
7	PAFZZ	96906	MS51957-17	.SCREW, MACHINE	8
8	PAFZZ	97403	13220E3542	.CONNECTOR, RECEPTACLE	4
9	XBFZZ	96906	MS3367-4-9	.STRAP,TIEDOWN	4
10	XAFZZ	97403	13220E3507	.PRINTED WIRING BOARD ASSY, A1	1
11	XAFZZ	97403	13220E3510	.PRINTED WIRING BOARD ASSY, A2	1
12	XAFZZ	97403	13220E3512	.PRINTED WIRING BOARD ASSY, A3	1
13	PAFZZ	97403	13220E3550-1	.PRINTED WIRING BOARD ASSY, A4	1
14	PAFZZ	97403	13220E3541	.CONNECTOR, PLUG	1
15	PAFZZ	97403	13220E4230	.SWITCH, PUSH	1
16	PAFZZ	96906	MS35333-40	.WASHER, LOCK, INTERNAL TOOTH	1
17	PAFZZ	97403	13220E3813	.LIGHT EMITTING DIAL (PWB)	1
18	XBFZZ	97403	13220E3506	.FRAME ASSY	1
19	XDFZZ	97403	13220E3520	.CARD GUIDE	8
20	PBFZZ	97403	13220E3607-1	.PLUG, CODE, PAIR	1
20	PBFZZ	97403	13220E3607-2	.PLUG, CODE, SET OF 3	1
21	PAFZZ	96906	MS35649-242	.NUT	8
22	PAFZZ	96906	MS35338-40	.WASHER, LOCK	8
23	PAFZZ	97403	13220E3508	.SCREW, CAPTIVE	4
				END OF FIGURE	

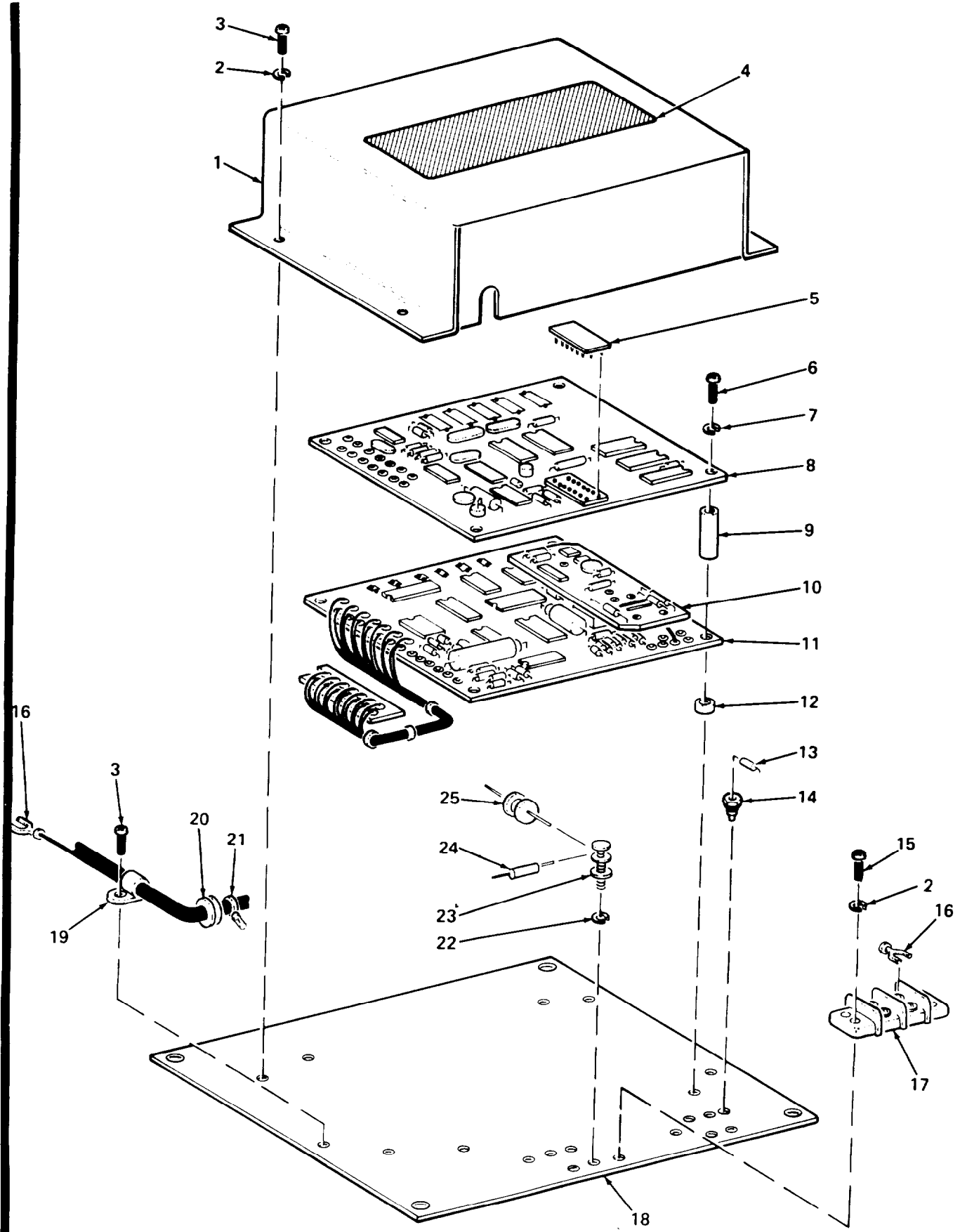

Figure 2. C-2 Data Transmitter T-1257/FSS-9(V)

SECTION II

(1) ITEM NO	(2) SMR CODE	(3) FSCM	(4) PART NUMBER	(5) DESCRIPTION AND USABLE ON CODES (UOC)	(6) QTY
				GROUP 02 DATA TRANSMITTER	
				FIG. C-2 DATA TRANSMITTER T-1257/FSS-9(V)	
1	XBFZZ	97403	13220E3605	CASE	1
2	PAFZZ	96906	MS35338-41	WASHER, LOCK	6
3	PAFZZ	96906	MS35206-226	SCREW, PANHEAD	5
				UOC:CWT	
4	XBFZZ	97403	13220E3606	PLATE, IDENTIFICATION	1
5	PBFZZ	97403	13220E3607-1	PLUG, CODE, PAIR	1
5	PBFZZ	97403	13220E3607-2	PLUG, CODE, SET OF 3	1
6	PAFZZ	96906	MS35206-222	SCREW, MACHINE	4
7	PAFZZ	96906	MS35338-40	WASHER, LOCK	4
8	XAFZZ	97403	13220E3603	CIRCUIT CARD ASSY	1
				UOC:CWT	
9	XBFZZ	97403	13220E3538-3	SPACER	4
10	XAFZZ	97403	13220E3604-1	CIRCUIT CARD ASSY	1
11	XAFZZ	97403	13220E3602	CIRCUIT CARD ASSY	1
12	XBFZZ	97403	13220E3538-5	SPACER	4
13	PAFZZ	97403	13220E4072	SEMICONDUCTOR DEVICE	2
14	PAFZZ	81349	MIL-T-55155/9	TERMINAL, STUD	4
15	PAFZZ	96906	MS35206-230	SCREW, MACHINE	2
16	XDFZZ	97403	13220E3829-1	TERMINAL	10
17	XBFZZ	97403	13220E3823-2	BARRIER STRIP	1
18	XBFZZ	97403	13220E3601	PLATE, BASE	1
19	XBFZZ	34785	MN-3	CLAMP, CABLE	1
20	XBFZZ	96906	MS35489-6	GROMMET	1
21	XBFZZ	96906	MS3367-4-9	STRAP, TIEDOWN	8
22	PAFZZ	96906	MS35333-36	WASHER, LOCK	2
23	XDFZZ	96906	MS17172-6	TERMINAL	2
24	PAFZZ	96906	MS75089-3	COIL, RADIO FREQUENCY	2
25	PPFZZ	71482	CG-75L	RESISTOR, VARIABLE, N	2
				END OF FIGURE	

TM 5-6350-264-14&P-12

NAVELEX EE 181-AA-OMI-13A/E121 R1861-T1257

TO 31S9-2FSS9-1-12

Section III. SPECIAL TOOLS LIST

(Not Applicable)

Section IV

NATIONAL STOCK NUMBER AND PART NUMBER INDEX

STOCK NUMBER	NATIONAL STOCK NUMBER INDEX		STOCK NUMBER	FIG.	ITEM
	FIG.	ITEM			
5310-00-045-4007	2	2			
5305-00-054-5651	1	7			
5310-00-193-7577	2	22			
5935-00-351-5928	1	8			
6350-00-368-8219	1	17			
5305-00-394-9586	1	23			
5310-00-543-2410	1	22			
	2	7			
5310-00-550-1130	1	16			
5930-00-839-4331	1	15			
5305-00-889-3000	2	15			
5305-00-889-3116	1	6			
5310-00-934-9739	1	21			
5305-00-958-5483	1	1			
5305-00-984-4979	2	6			
5305-00-984-4983	2	3			
5905-01-005-6371	2	25			
5950-01-008-8645	2	24			
5940-01-031-1027	2	14			
6350-01-071-5519	1	20			
	2	5			
6350-01-071-5520	1	20			
	2	5			
5935-01-080-6321	1	14			
5961-01-141-5110	2	13			
6350-01-157-6521	1	13			

TM 5-6350-264-14&P-12

NAVELEX EE 181-AA-OMI-13A/E121 R1861-T1257

TO 31S9-2FSS9-1-12

SECTION IV (Cont)

NATIONAL STOCK NUMBER AND PART NUMBER INDEX

FSCM	PART NUMBER	PART NUMBER INDEX STOCK NUMBER	FIG.	ITEM
71482	CG-75L	5905-01-005-6371	2	25
81349	MIL-T-55155/9	5940-01-021-1027	2	14
34785	MN-3		2	19
96906	MS17172-6		2	23
96906	MS3367-4-9		1	9
			2	21
96906	MS35190-221	5305-00-958-5483	1	1
96906	MS35206-213	5305-00-889-3116	1	6
96906	MS35206-222	5305-00-984-4979	2	6
96906	MS35206-226	5305-00-984-4983	2	3
96906	MS35206-230	5305-00-889-3000	2	15
96906	MS35333-36	5310-00-193-7577	2	22
96906	MS35333-40	5310-00-550-1130	1	16
96906	MS35338-40	5310-00-543-2410	1	22
			2	7
96906	MS35338-41	5310-00-045-4007	2	2
96906	MS35489-6		2	20
96906	MS35649-242	5310-00-934-9739	1	21
96906	MS51957-17	5305-00-054-5651	1	7
96906	MS75089-3	5950-01-008-8645	2	24
97403	13220E3502		1	2
97403	13220E3503-1		1	4
97403	13220E3504		1	5
97403	13220E3506		1	18
97403	13220E3507		1	10
97403	13220E3508	5305-00-394-9586	1	23
97403	13220E3510		1	11
97403	13220E3512		1	12
97403	13220E3520		1	19
97403	13220E3536		1	3
97403	13220E3538-3		2	9
97403	13220E3538-5		2	12
97403	13220E3541	5935-01-080-6321	1	14
97403	13220E3542	5935-00-351-5928	1	8
97403	13220E3550-1	6350-01-157-6521	1	13
97403	13220E3601		2	18
97403	13220E3602		2	11
97403	13220E3603		2	8
97403	13220E3604-1		2	10
97403	13220E3605		2	1
97403	13220E3606		2	4
97403	13220E3607-1	6450-01-071-5520	1	20
			2	5
97403	13220E3607-2	6350-01-071-5519	1	20
			2	5
97403	13220E3813	6350-00-368-3219	1	17
97403	13220E3823-2		2	17
97403	13220E3829-1		2	16
97403	13220E4072	5961-01-141-5110	2	13
97403	13220E4230	5930-00-839-4231	1	15

By Order of the Secretaries of the Army, the Navy, and the Air Force:

Official:

ROBERT M. JOYCE
Brigadier General, United States Army
The Adjutant General

E. C. MEYER
General, United States Army
Chief of Staff

Official:

JAMES P. MULLINS
General, USAF, Commander, Air Force
Logistics Command

H. D. ARNOLD
Rear Admiral, United State Navy
Commander, Naval Electronic
Systems Command

CHARLES A. GABRIEL, General, USAF
Chief of Staff

DISTRIBUTION:

To be distributed in accordance with DA Form 12-25A, Operator Maintenance requirements for Intrusion Detection.

RECOMMENDED CHANGES TO EQUIPMENT TECHNICAL PUBLICATIONS



SOMETHING WRONG WITH THIS PUBLICATION?

THEN... JOT DOWN THE DOPE ABOUT IT ON THIS FORM. CAREFULLY TEAR IT OUT. FOLD IT AND DROP IT IN THE MAIL!

FROM: (PRINT YOUR UNIT'S COMPLETE ADDRESS)

PFC JOHN DOE
COA, 3d ENGINEER BN
FT. LEAVENWORTH, MO 63108

DATE SENT

PUBLICATION NUMBER

TM 5-6350-264-14&P-12

PUBLICATION DATE

30 Aug 82

PUBLICATION TITLE

Receiver and Transmitter

BE EXACT. PIN-POINT WHERE IT IS

PAGE NO	PARA-GRAPH	FIGURE NO	TABLE NO
6	2-1 a		
B1		4-3	
125	line 20		

IN THIS SPACE TELL WHAT IS WRONG AND WHAT SHOULD BE DONE ABOUT IT:

In line 6 of paragraph 2-1a the manual states the engine has 6 cylinders. The engine on my set only has 4 cylinders. Change the manual to show 4 cylinders.

Callout 16 on figure 4-3 is pointing at a bolt. In key to figure 4-3, item 16 is called a shim. Please correct one or the other.

I ordered a gasket, item 19 on figure B-16 by NSN 2 910-00-762-3001. I got a gasket but it doesn't fit. Supply says I got what I ordered, so the NSN is wrong. Please give me a good NSN

PRINTED NAME, GRADE OR TITLE, AND TELEPHONE NUMBER

JOHN DOE, PFC (268) 317-7111

SIGN HERE

JOHN DOE

DA FORM 1 JUL 79 2028-2

PREVIOUS EDITIONS ARE OBSOLETE.
DRSTS-M Overprint 1, 1 Nov 80

P.S.--IF YOUR OUTFIT WANTS TO KNOW ABOUT YOUR RECOMMENDATION MAKE A CARBON COPY OF THIS AND GIVE IT TO YOUR HEADQUARTERS

TEAR ALONG PERFORATED LINE

FILL IN YOUR
UNIT'S ADDRESS

FOLD BACK

DEPARTMENT OF THE ARMY

OFFICIAL BUSINESS
PENALTY FOR PRIVATE USE \$300

POSTAGE AND FEES PAID
DEPARTMENT OF THE ARMY
DOD 314



COMMANDER
U S ARMY SUPPORT AND AVIATION MATERIEL READINESS COMMAND
ATTN: DRSTS-MPSD
4300 GOODFELLOW BOULEVARD
ST. LOUIS, MO 63120

TEAR ALONG PERFORATED LINE

The Metric System and Equivalents

Linear Measure

1 centimeter = 10 millimeters = .39 inch
 1 decimeter = 10 centimeters = 3.94 inches
 1 meter = 10 decimeters = 39.37 inches
 1 dekameter = 10 meters = 32.8 feet
 1 hectometer = 10 dekameters = 328.08 feet
 1 kilometer = 10 hectometers = 3,280.8 feet

Weights

1 centigram = 10 milligrams = .15 grain
 1 decigram = 10 centigrams = 1.54 grains
 1 gram = 10 decigrams = .035 ounce
 1 dekagram = 10 grams = .35 ounce
 1 hectogram = 10 dekagrams = 3.52 ounces
 1 kilogram = 10 hectograms = 2.2 pounds
 1 quintal = 100 kilograms = 220.46 pounds
 1 metric ton = 10 quintals = 1.1 short tons

Liquid Measure

1 centiliter = 10 milliliters = .34 fl. ounce
 1 deciliter = 10 centiliters = 3.38 fl. ounces
 1 liter = 10 deciliters = 33.81 fl. ounces
 1 dekaliter = 10 liters = 2.64 gallons
 1 hectoliter = 10 dekaliters = 26.42 gallons
 1 kiloliter = 10 hectoliters = 264.18 gallons

Square Measure

1 sq. centimeter = 100 sq. millimeters = .155 sq. inch
 1 sq. decimeter = 100 sq. centimeters = 15.5 sq. inches
 1 sq. meter (centare) = 100 sq. decimeters = 10.76 sq. feet
 1 sq. dekameter (are) = 100 sq. meters = 1,076.4 sq. feet
 1 sq. hectometer (hectare) = 100 sq. dekameters = 2.47 acres
 1 sq. kilometer = 100 sq. hectometers = .386 sq. mile

Cubic Measure

1 cu. centimeter = 1000 cu. millimeters = .06 cu. inch
 1 cu. decimeter = 1000 cu. centimeters = 61.02 cu. inches
 1 cu. meter = 1000 cu. decimeters = 35.31 cu. feet

Approximate Conversion Factors

<i>To change</i>	<i>To</i>	<i>Multiply by</i>	<i>To change</i>	<i>To</i>	<i>Multiply by</i>
inches	centimeters	2.540	ounce-inches	newton-meters	907062
feet	meters	.305	centimeters	inches	.394
yards	meters	.914	meters	feet	3.260
miles	kilometers	1.609	meters	yards	1.094
square inches	square centimeters	6.451	kilometers	miles	.621
square feet	square meters	.093	square centimeters	square inches	.155
square yards	square meters	.836	square meters	square feet	10.764
square miles	square kilometers	2.590	square meters	square yards	1.196
acres	square hectometers	.405	square kilometers	square miles	.386
cubic feet	cubic meters	.028	square hectometers	acres	2.471
cubic yards	cubic meters	.765	cubic meters	cubic feet	35.315
fluid ounces	milliliters	29.573	cubic meters	cubic yards	1.308
pints	liters	.473	milliliters	fluid ounces	.034
quarts	liters	.946	liters	pints	2.113
gallons	liters	3.785	liters	quarts	1.057
ounces	grams	28.349	liters	gallons	.264
pounds	kilograms	.454	grams	ounces	.035
short tons	metric tons	.907	kilograms	pounds	2.205
pound-feet	newton-meters	1.356	metric tons	short tons	1.102
pound-inches	newton-meters	.11296			

Temperature (Exact)

°F	Fahrenheit	5/9 (after	Celsius	°C
	temperature	subtracting 32)	temperature	

PIN: 051401-001